



EX-919xxCP Series

10.1", 15.6", and 21.5" Intel Tiger Lake
Fanless Industrial Compact Size Panel PC

User Manual

Release Date

March, .2023
©TOPSCCC Technology CO., LTD

Revision

V1.1
All Rights Reserved.

Revision History

Reversion	Date	Description
1.0	2023/05/17	Initiation

Warning!

This equipment generates uses and can radiate radio frequency energy and if not installed and used in accordance with the instructions manual, it may cause interference to radio communications. It has been tested and found to comply with the limits for a Class A computing device pursuant to FCC Rules, which are designed to provide reasonable protection against such interference when operated in a commercial environment. Operation of this equipment in a residential area is likely to cause interference in which case the user at his own expense will be required to take whatever measures may be required to correct the interference.

Electric Shock Hazard – Do not operate the machine with its back cover removed. There are dangerous high voltages inside.

Caution

Risk of explosion if the battery is replaced with an incorrect type.

Batteries should be recycled where possible. Disposal of used batteries must be in accordance with local environmental regulations.

Disclaimer

This information in this document is subject to change without notice. In no event shall Tops CCC Technology CO., Ltd.be liable for damages of any kind, whether incidental or consequential, arising from either the use or misuse of information in this document or in any related materials.

Safety Precautions

Follow the messages below to prevent your systems from damage:

- ◆ Avoid your system from static electricity on all occasions.

- ◆ Prevent electric shock. Don't touch any components of this card when the card is power-on.
Always disconnect power when the system is not in use.

- ◆ Disconnect power when you change any hardware devices. For instance, when you connect a jumper or install any cards, a surge of power may damage the electronic components or the whole system.

Table of Contents

Warning!	1
Safety Precautions	2
Chapter 1 System Product	5
1.1 Features	5
1.2 Specifications	6
1.3 COM port definition	8
1.4 Standard LCD	9
1.5 High Brightness LCD	9
1.6 Power Consumption and PoE Application	10
1.7 Dimensions	11
1.8 Brief Description of EX-919XXCP Series	12
1.9 VESA Mounting	16
1.10 Panel Mounting	17
1.11 Cable Cover	19
1.12 Battery Kit Installation	21
1.13 MB Box kit attaches to the Front Kit	22
1.14 Warning for separating EX-919xxCP BOX PC	23
1.15 Warning of HDMI/DP port insert	23
Chapter 2 Hardware	24
2.1 Specifications	24
2.2 Board Overview	28
2.3 Jumpers Setting and Connectors	30
Chapter 3 BIOS Setup Description	38
3.1 Overview	38
3.2 Main Settings	40
3.3 Advanced Settings	41
3.4 Chipset Settings	51
3.5 Security Settings	56
3.6 Boot Settings	58
3.7 Save & Exit Settings	59
Chapter 4 Installation of Drivers	61
4.1 Intel Chipset	62
4.2 Intel® HD Graphics Chipset	64
4.3 Realtek HD Audio Driver Installation	66
4.4 Intel LAN Driver	67
4.5 Intel® Serial I/O	69

4.6 Intel® Management and Security Status Installer	72
4.7 Intel® Management Engine Components	73
4.8 Intel® HID Event Filter	75

List of Figures

FIGURE 1 DIMENSIONS OF EX-91910CP	11
FIGURE 2 DIMENSIONS OF EX-91916CP	11
FIGURE 3 DIMENSIONS OF EX-91921CP	12
FIGURE 4 FRONT VIEW OF EX-91910CP(H)	13
FIGURE 5 REAR VIEW OF EX-91910CP(H)	13
FIGURE 6 FRONT VIEW OF EX-91916CP(H)	14
FIGURE 7 REAR VIEW OF EX-91916C(H)	14
FIGURE 8 FRONT VIEW OF EX-91921CP(H)	15
FIGURE 9 REAR VIEW OF EX-91921CP(H)	15
FIGURE 10 EX-91910CP VESA MOUNTING	16
FIGURE 11 EX-91916CP/EX-91921CP VESA MOUNTING	16
FIGURE 12 EX-91910CP PANEL MOUNTING	17
FIGURE 13 EX-91916CP/EX-91921CP PANEL MOUNTING	18
FIGURE 14 EX-91916CP/EX-91921CP CABLE COVER INSTALLATION	20
FIGURE 15 EX-91910CP MB BOX KIT ATTACHES TO FRONT KIT	22
FIGURE 16 EX-91916CP/921C MB BOX KIT ATTACHES TO FRONT KIT	22
FIGURE 17 HDMI-9C BOX PC SEPARATION WARNINGS	23
FIGURE 18 HDMI/DP PORT INSERT INSTRUCTION WARNING	23

1.1 Features

- ★ 10.1", 15.6" and 21.5" Intel® 11th Fanless HMI Panel PC
- ★ Gap-free sealing and slim Front Frame Architecture and front panel
- ★ DC 9~36V wide-ranging power input
- ★ IP66 compliant front panel
- ★ Support High brightness LCD (option)

1.2 Specifications

EX-919xxCP	
System	
CPU	Intel 11 th Gen. Core i5/i3 Processors Core i3-1115G4E (2C, 2.20 GHz, up to 3.90GHz, TDP-up 28W) Core i5-1145G7E (4C, 1.50 GHz, up to 4.10GHz, TDP-up 28W) Celeron® 6305UE(2C, 1.80GHz, TDP 15W)by project base
Chipset	SoC
Memory	2 x DDR4 SO-DIMM slot, 3200MHz, up to 64GB
LVDS	1 x 18/24 bit Dual Channel onboard
eDP	1 x eDP reserved for panel (eDP interface)
IO Port	
USB	4 x USB 3.2 type A
Serial/Parallel	1 x RS-232 pin1 RTS/5V/12V selectable via jumper (COM1), 1 x RS-232/422/485 port (COM2), in 1x DB9 connector (COM1_2)
Audio	1 x Audio Line Out
LAN	2 x GbE LAN RJ-45 (i5 support vPro, option)
Power	1 x 3-pin DC Power Input terminal 1 x 2-pin connector for power on/off button
Display port	1 x DP/HDMI
Option	<ol style="list-style-type: none"> 1. 4 x USB 2.0 type A 2. 4 x USB 2.0 type A + 1 x Mini-PCle + 1 x SIM slot 3. 2 x COM(RS-232) 4. 1 x COM*RS-232) + 2 x USB 2.0 5. 1 x COM(RS-232) + 2 x USB2.0 + 1 x Power Button 6. 2 x CAN 7. 2 x COM(RS-232) + 1 x Mini-PCle slot

	<ol style="list-style-type: none"> 8. 2 x COM (RS-422/485, isolated) 9. 1 x LAN + 2 x USB 2.0 type A <ul style="list-style-type: none"> ☞ Auto Dimming (Exclusive LED indicator) ☞ GPIO (4xDI, 4xDO) ☞ WIFI (Through M.2 E Key) ☞ Cable Cover (above 15.6")
Storage Space	

Storage	1 x M.2 2280 M Key (PCIex4/SATA III), support NVME SSD 1 x 2.5" SATAIII HDD (Option, exclusive of TB528 series, battery)
Expansion	
Expansion Slot	1 x M.2 2230 E-Key socket for optional Wi-Fi/BT Module (PCIex2+USB 2.0) 1 x Full-size Mini-PCIe slot 1 x Nano SIM card holder
Touch Screen – Projected Capacitive Type	
TS Control	COF
Interface	USB
Light Transmission	90%
Wireless LAN and Antenna	
Wireless LAN	Wifi 4/5/6e via M.2 Key module card (option)
Antenna	4 x SMA-female connector's holes for external antenna (default 2 antenna)
Power	
Power Input	DC 9~36V
Backup Battery	
Backup battery	3250mAh(option) *When the Backup battery is installed; it cannot run full loading program; it may cause the system shot down
Mechanical	
Mechanical Construction	Aluminum die-casting chassis
Front Bezel Metal	Aluminum/Panel Mounting
Mounting	VESA Mount 100 x 100
Chassis Color	Black
IP Rating	Front Panel IP66
Operating System Support	
OS Support	Windows 10 IoT Windows 11 Linux Ubuntu 20.04 above
Environmental	
Operating Temperature	0~50°C/-20°C to 60°C (optional for 10.1", 15.6")

Storage Temperature	-30~70°C
Humidity	10 to 95% @ 40°C, non-condensing
Certification	CE / FCC Class A, RoHS/REACH Compliant

*Please make sure the input voltage measured from the “power input connector” is more than 9 volt; to keep the product work properly.

1.3 COM port definition

Pin#	COM1 (RS232)	COM2 (RS232)	COM2 (RS422)	COM2 (RS485)
1	RTS/5V/12V			
2	RX			
3	TX			
4	CTS			
5	GND	GND		
6		<u>TX</u>	<u>RX+</u>	
7			<u>RX-</u>	
8			<u>TX-</u>	<u>D-</u>
9		<u>RX</u>	<u>TX+</u>	<u>D+</u>

1x RS232, pin1 RTS/5V/12V selectable via jumper (COM1), jumper setting please refer to the [18. JP2](#): 1x RS232/422/485 port(COM2), in 1xDB9 connector (COM1_2)

2507009001000000	COM port Y cable DSUB/DSUB 9P(F) TO (M)×2 FOR Volt /RS232 L=10cm	Default
4507009001000001	COM port Y cable (optional) DSUB/DSUB 9P(F) TO (M)×2 FOR RTS L=10cm	Optional

WARNING: If the wrong Y cable is used, it may damage the device

1.4 Standard LCD

	EX-91910CP	EX-91916CP	EX-91921CP
Display Type	10.1" LED Backlight	15.6" LED Backlight	21.5" LED Backlight
Max. Resolution	1280 x 800	1366 x 768 1920 x 1080	1920 x 1080
Max. Color	16.7M	16.7M	16.7M
Luminance(cd/m ²)	350	400-HD 500-FHD	250
Contrast Ratio	800:1	500:1-HD 1000:1-FHD	1000:1
Viewing angle(H/V)	170 /170	170 / 160-HD 178 / 178-FHD	178 / 178
Backlight Lifetime (Hrs)	30,000	50,000	50,000
Power Consumption	MAX:56W	MAX:60W	MAX:86W
Mounting	VESA Mount 100 x 100(mm)		
Dimensions(mm)	269x189x51	405x256x59	541x 333 x 59
Net Weight (Kg)	2.8	4.4	6.3

1.5 High Brightness LCD

	EX-91910CP	EX-91916CP	EX-91921CP
Display Type	10.1" LED Backlight	15.6" LED Backlight	21.5" LED Backlight
Max. Resolution	1280 x 800	1366 x 768 1920 x 1080	1920 x 1080
Max. Color	16.7M	16.7M	16.7M
Luminance(cd/m ²)	350	400-HD 500-FHD	250
Contrast Ratio	800:1	500:1-HD 1000:1-FHD	1000:1
Viewing angle(H/V)	170 /170	170 / 160-HD 178 / 178-FHD	178 / 178
Backlight Lifetime (Hrs)	30,000	50,000	50,000
Power Consumption	MAX:56W	MAX:60W	MAX:86W
Mounting	VESA Mount 100 x 100(mm)		
Dimensions(mm)	269x189x51	405x256x59	541x 333 x 59
Net Weight (Kg)	2.8	4.4	6.3

1.6 Power Consumption and PoE Application

Max power consumption of each model

Model	Max Power Consumption	PoE++(45W)
EX-91910CP	51.91	y*
EX-91916CP	96.37	n
EX-91921CP	101.08	n

- * Max Power Consumption: Backlight bright setting 100%,+Turbo on+ System full loading with full rear IO connectors.
- * Power consumption may have 10% tolerance difference due to different MB, parts, test instrument, and so on.
- * y* means: system turbo off+ rear IO no loading+ LED backlight down to 70%, and the PSE cable connect to the system needs to be shorter than 50m. If you need some IO loading, please find your sales representative to discuss.
- * y* does not apply in Linux OS.
- * We suggest to use the adapter that TOPSCCC approved. If you would like to adopt your own power supply or adapter, please add another 20-30% from the above power consumption to make sure the system can work correctly.

1.7 Dimensions

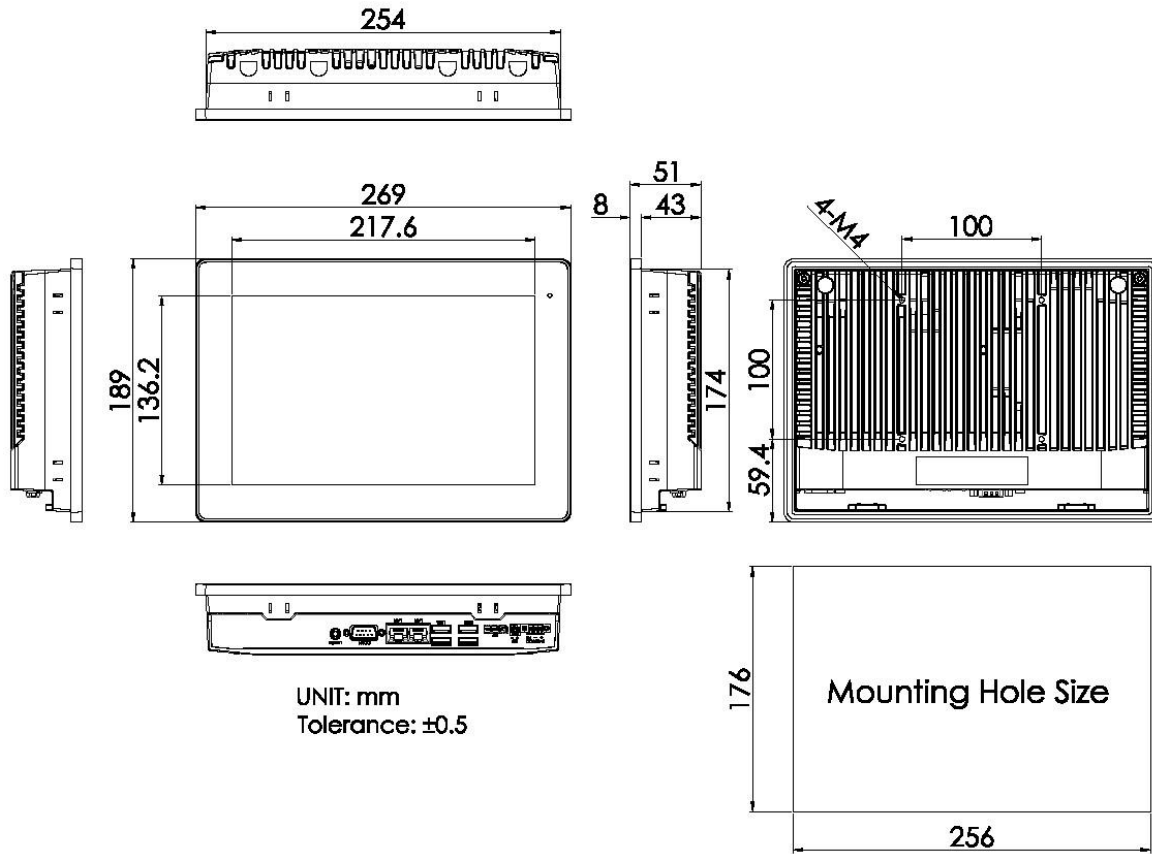

Figure 1 Dimensions of EX-91910CP

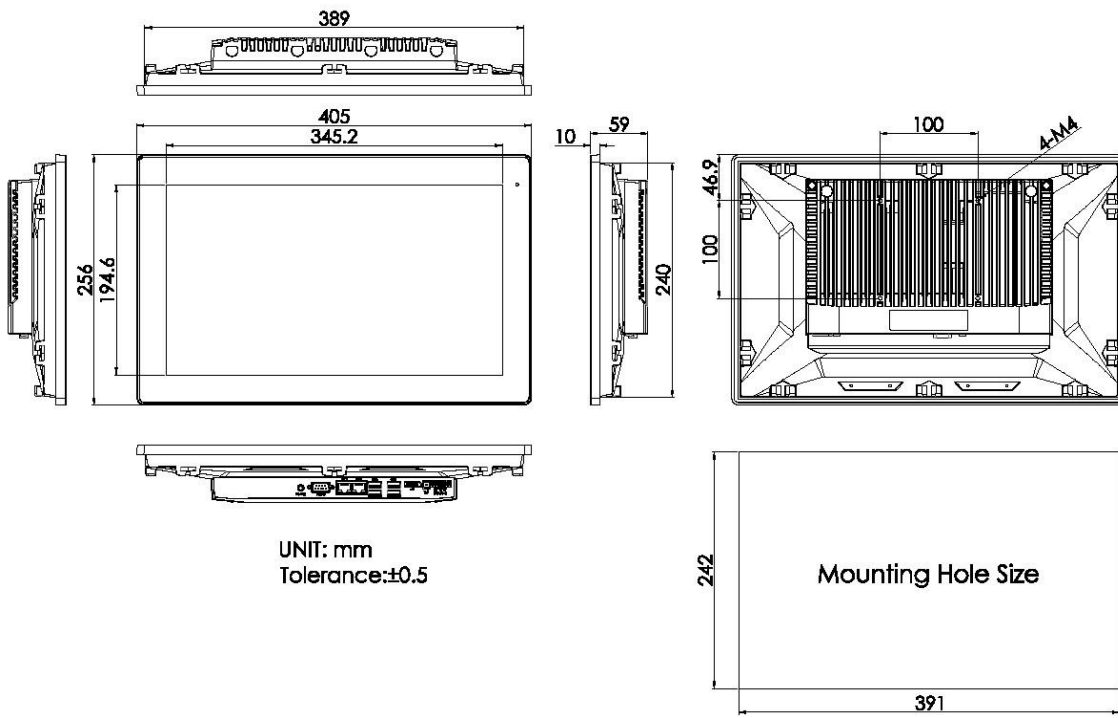

Figure 2 Dimensions of EX-91916CP

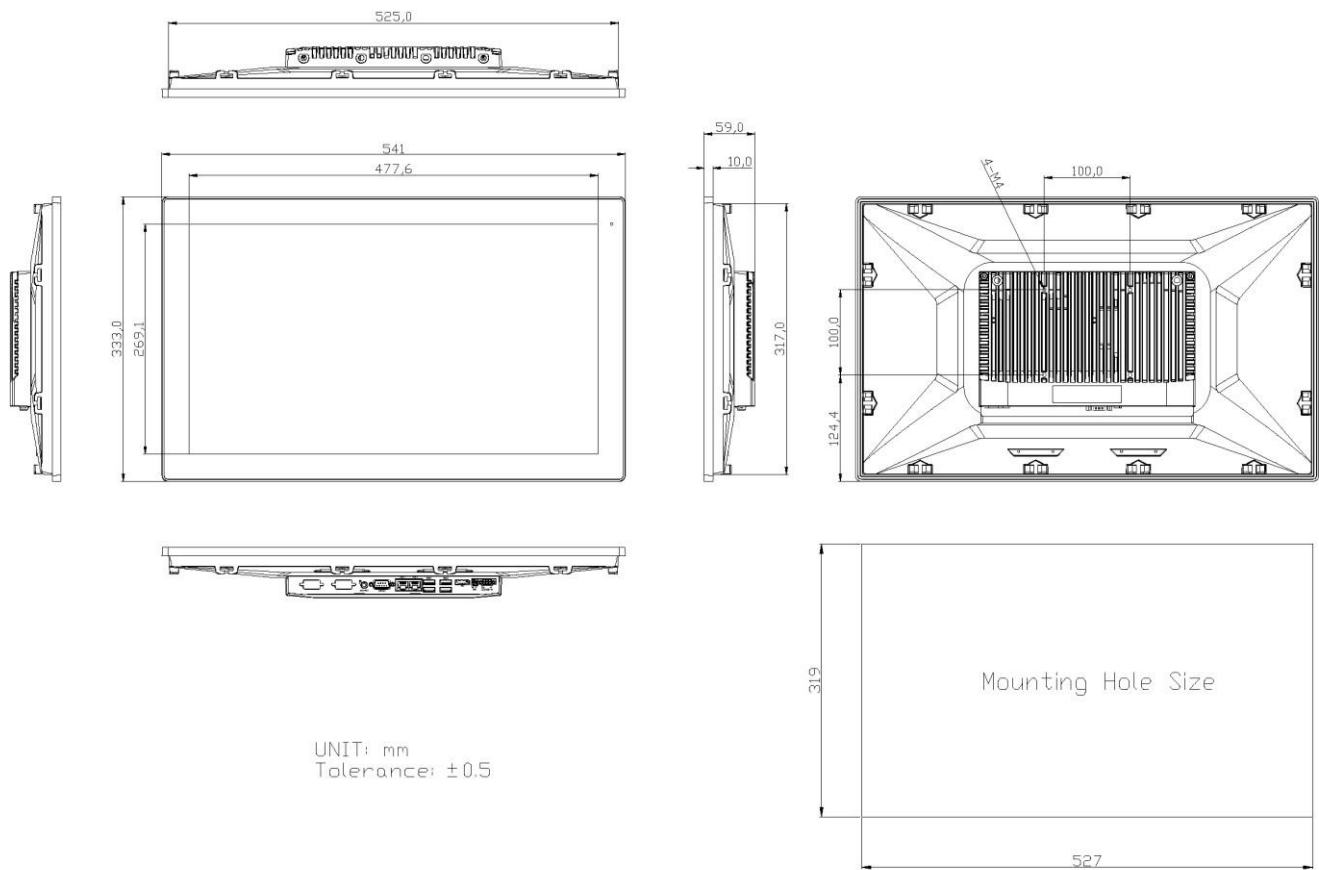

Figure 3 Dimensions of EX-91921CP

1.8 Brief Description of EX-919XXCP Series

There are 10.1" ~ 21.5" Industrial Compact Size Panel PC in EX-919XXCP series, which comes with flat front panel touch screen and fanless design. It is powered by Intel 11th Generation Core i3/i5 CPU Processors with two SO-DIMM DDR4 slot, up to 64GB 3200 MHz. These systems support DC 9~36V wideranging power input and IP66 compliant front panel. Optional projected capacitive touch support 7H antiscratch surface is ideal for use as PC-based controller for Industrial Automation & Factory Automation. Furthermore, EX-919xxCP Series are capable of expanding the function by option expansion I/O boards, TB528 series, includes Mini-PCIe, CAN bus, POE, USB, and isolation I/O module to improve competitive advantage through providing critical flexibility and expansibility for the variety of application and requirement.



Figure 4 Front View of EX-91910CP(H)



Figure 5 Rear View of EX-91910CP(H)



Figure 6 Front View of EX-91916CP(H)



Figure 7 Rear View of EX-91916CP(H)



Figure 8 Front View of EX-91921CP(H)



Figure 9 Rear View of EX-91921CP(H)

1.9 VESA Mounting

1.9.1. 10.1"

The EX-91910CP is designed to be VESA mounted as shown in Picture. Just carefully place the unit through the hole and tighten the given 4 x M4x8 screws from the rear to secure the mounting.

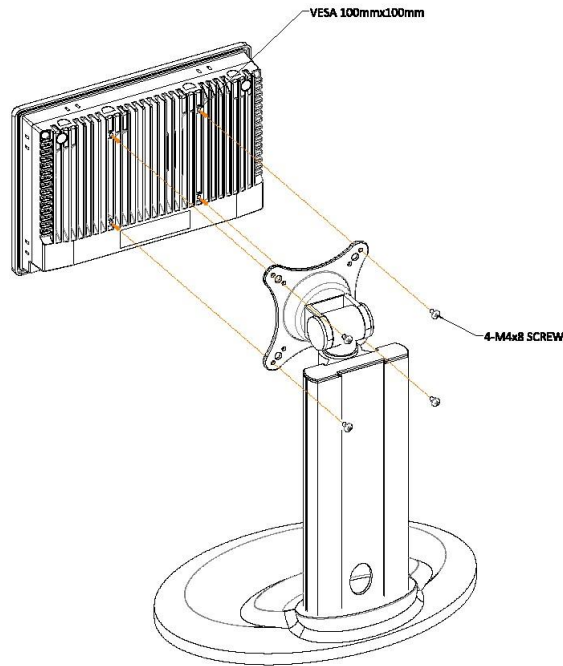

Figure 10 EX-91910CP VESA Mounting

1.9.2. 15.6" and 21.5"

The EX-91916CP and EX-91921CP are designed to be VESA mounted as shown in Picture. Just carefully place the unit through the hole and tighten the given 4 x M4x8 screws from the rear to secure the mounting.

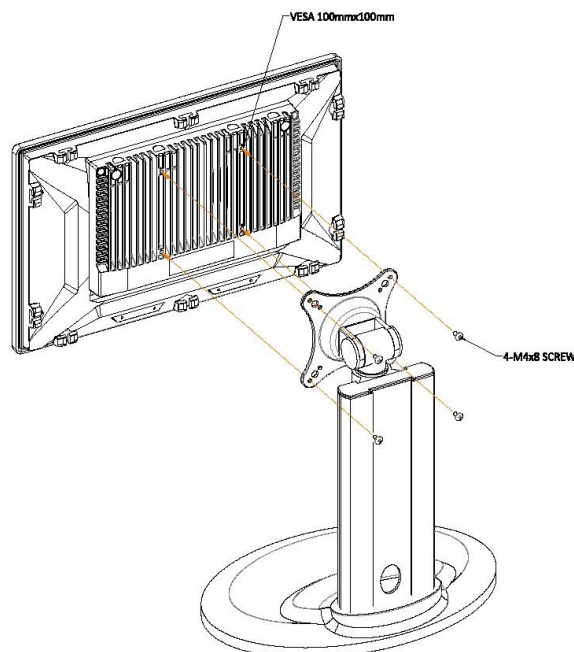

Figure 11 EX-91916CP/EX-91921CP VESA Mounting

1.10 Panel Mounting

1.10.1. 10.1”

Step1: Embed the main EX-91910CP machine into the panel frame.

Step2: Insert the latch into the specific hole on EX-91910CP.

Step3: Fix the latch with screw.

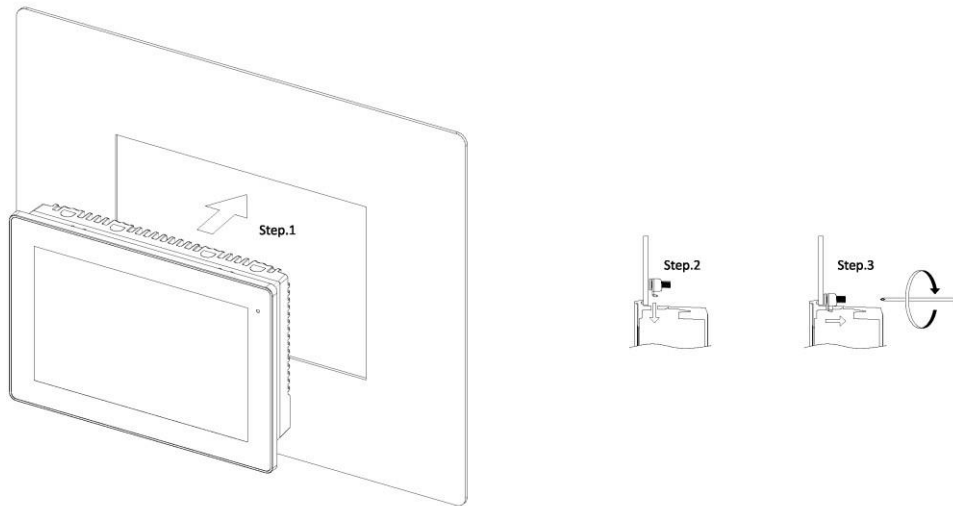
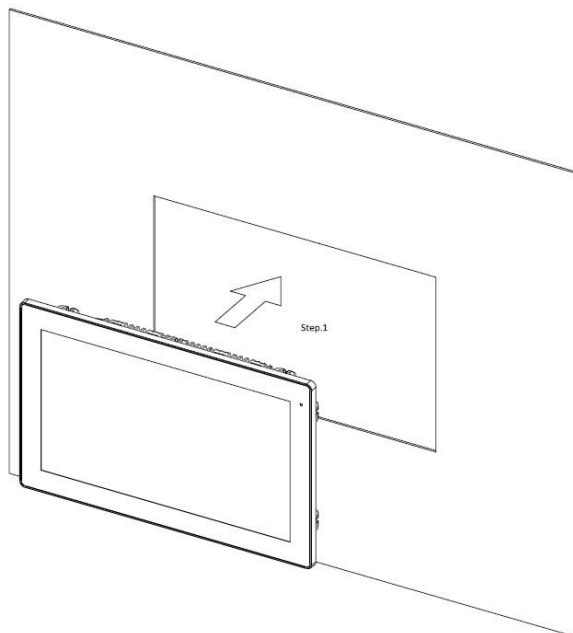

Figure 12 EX-91910CP Panel Mounting

1.10.2. 15.6” and 21.5”

Step1: Embed the main EX-91916CP/921CP machine into the panel frame.



Step2: Insert the latch into the specific hole on EX-91916CP/921C.(The mounting kits are different from EX-91910CP)

Step3: Fix the latch with screw.

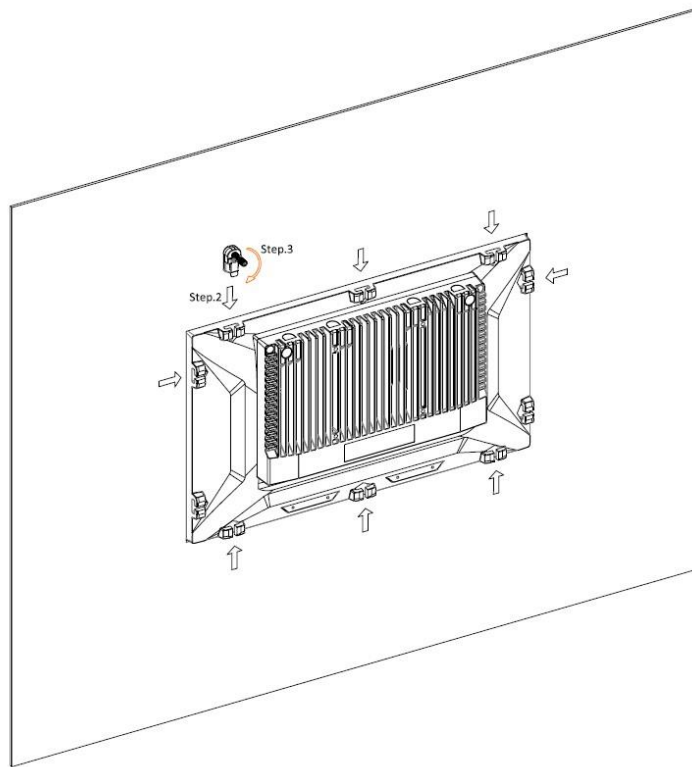

Figure 13 EX-91916CP/EX-91921CP Panel Mounting

1.11 Cable Cover

Due to natural mechanical limits, cable cover only fits 15.6" and 21.5" model.

Turn the two small brackets into two sides to separate from 15.6" and 21.5" printing.

Step 0: Please take care the L sharp bracket must install in accordance with the product mode.

If you would like to install the cable cover into 15.6", the mark "916" should lie on the frame as below drawing. And the rule for the 21.5 inch.

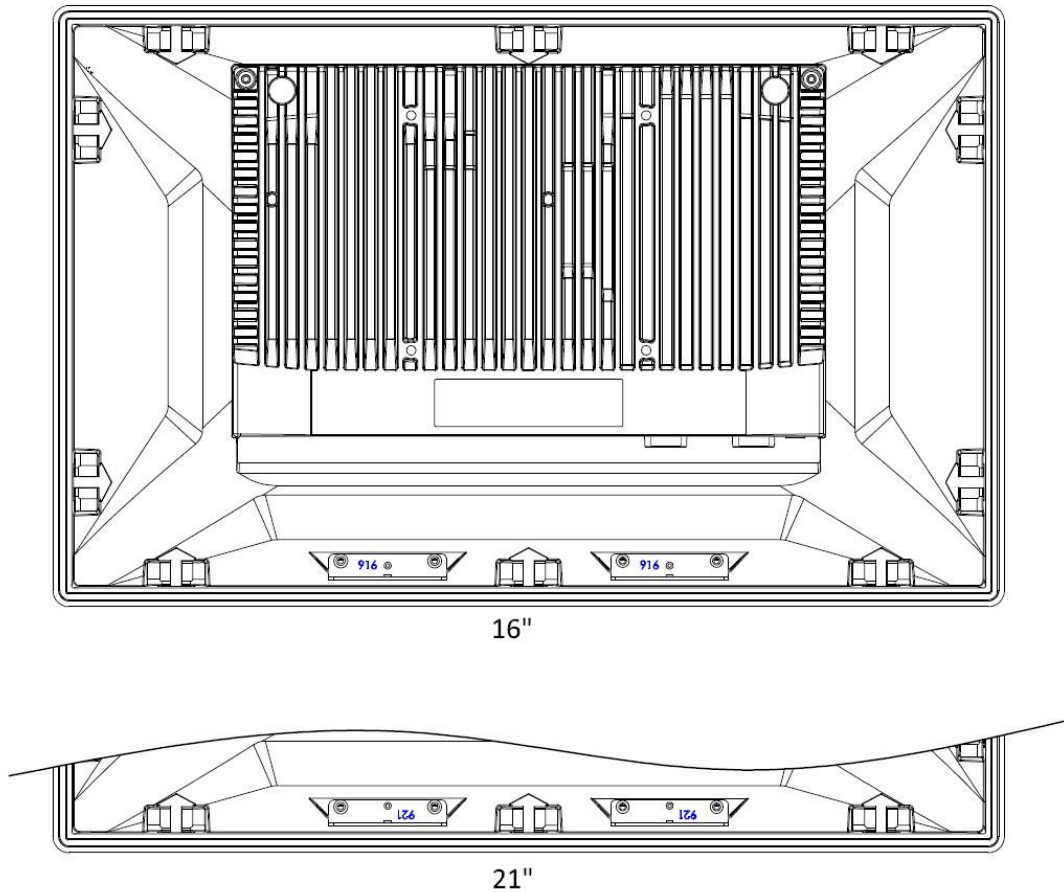

Step1: Insert the cover via the two brackets onto machine.

Step2: Fix the cover with 2x M3x6 screws.

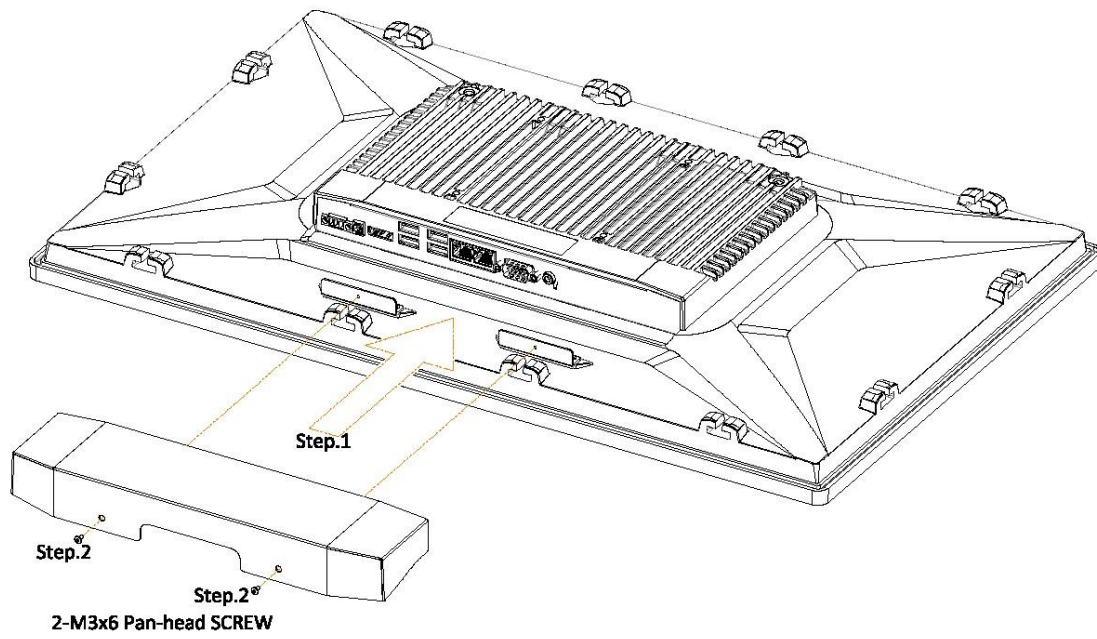
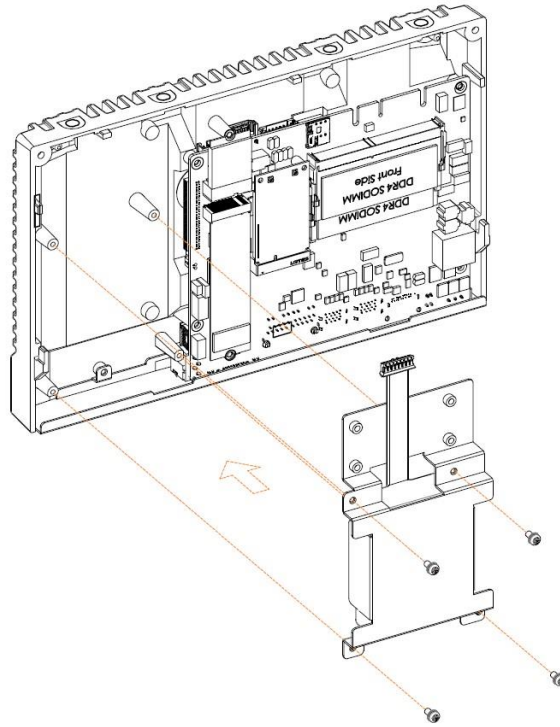

Figure 14 EX-91916CP/EX-91921CP Cable Cover Installation

1.12 Battery Kit Installation

Step1: Insert the battery kit to the MB box kit and screw it with 4pcs M3x6 screws.



Step2: Connect the battery cable to the MB connector.

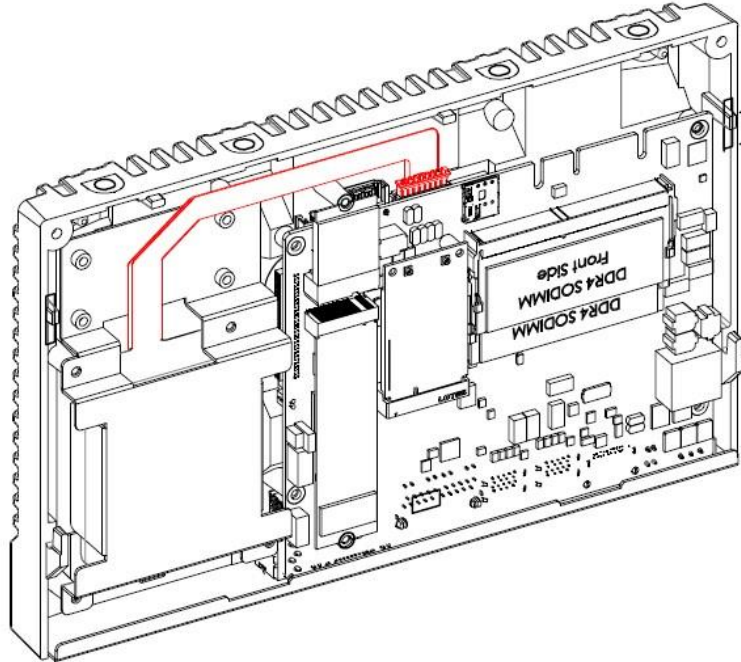

1.13 MB Box kit attaches to the Front Kit

This part fits for all 10.1", 15.6" and 21.5" models.

Step1: Insert the MB Box Kit to the Front Kit.

Step2: Use 2x M3x6 Pan-head screw to fix MB Box kit with Front kit at both left side and right side.

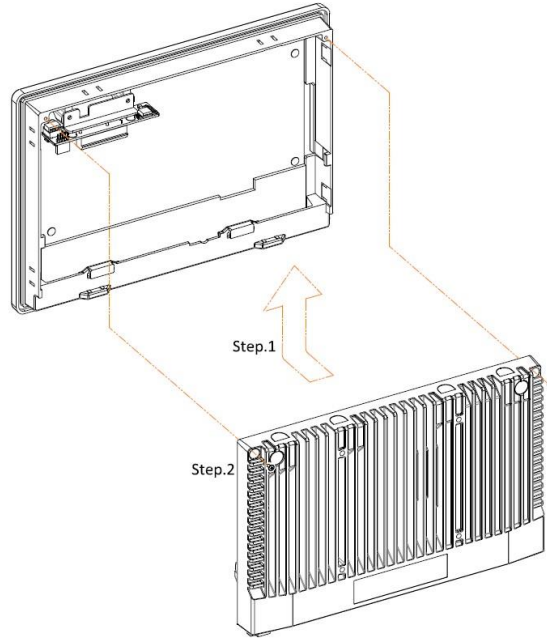

Figure 15 EX-91910CP MB Box kit attaches to Front Kit

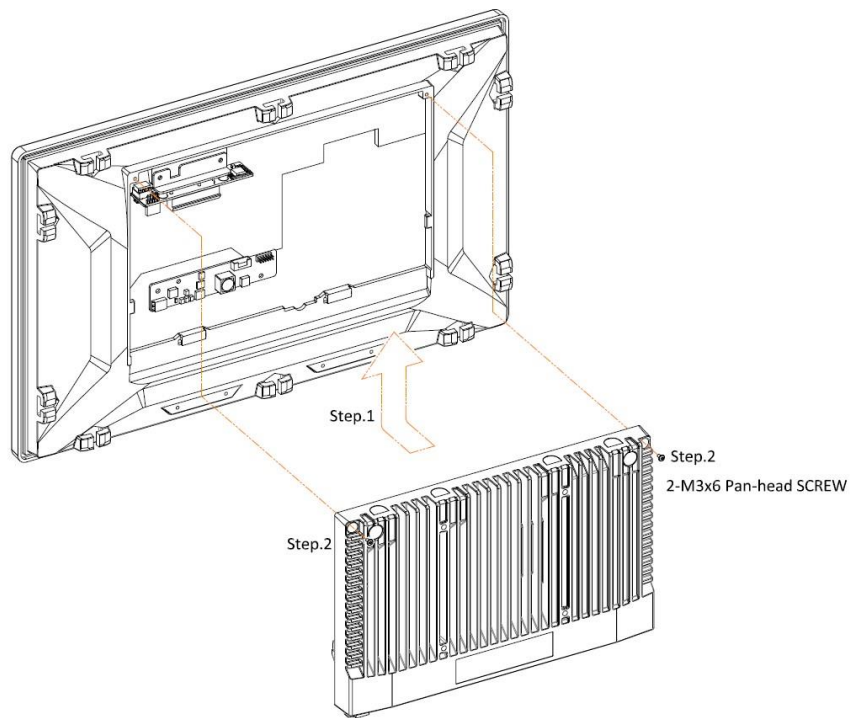

Figure 16 EX-91916CP/921CP MB Box kit attaches to Front Kit

1.14 Warning for separating I BOX PC

Step1: Recognize BOX PC is the blue one shown as picture above.

Step2: Separate the BOX PC from Front Kit slightly.

Step3: Separate successfully.

Note: It may cause the M.2 space copper pillar damage if separate roughly.

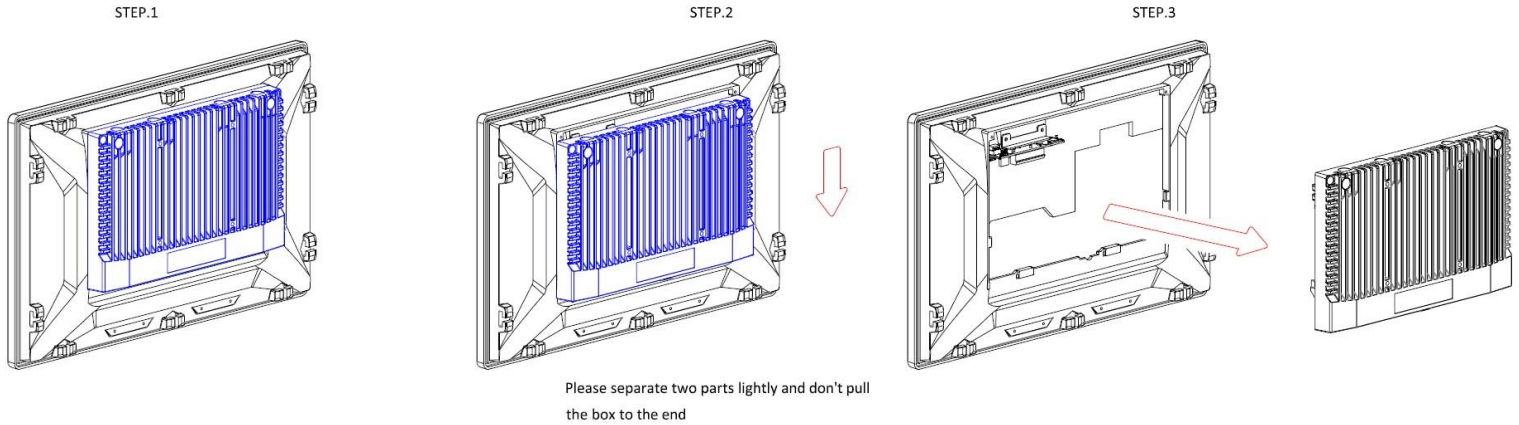

Figure 17 EX-919xxPC BOX PC separation warnings

1.15 Warning of HDMI/DP port insert

Important:

Please be cautious when inserting an HDMI cable into the HDMI/DP port. The HDMI male connector shall align to the left of the port as illustrated here. The insertion is fairly effortless and please reframe from forcing the insertion to prevent damage.



Figure 18 HDMI/DP port insert instruction warning

The industrial motherboard developed on the basis of Intel Core I Processors, which provides abundant peripheral interfaces to meet the needs of different customers. Also, it features dual RJ45 connectors, 6-COM ports and one M.2 M-Key configuration, one DP/HDMI combo connector, one LVDS interface. To satisfy the special needs of highend customers, 1 x M.2 E-Key slot and 1 x mini PCIe richer extension functions. The product is widely used in various sectors of industrial control.

2.1 Specifications

Specifications	
Board Size	155mm x 125mm
CPU Support	Intel® Core™ i3-1115G4E(2C/4T, 2.20 up to 3.90GHz) Intel® Core™ i5-1145G7E(4C/8T,1.50 up to 4.10GHz) Intel® Celeron 6305UE(2C/2T, 1.80 GHz)
Chipset	SOC
Memory Support	2x 260pin dual channel SO-DIMM up to 64GB DDR4 3200MHz
Graphics	Intel® Iris® X (i5-1145G7E) Intel® UHD Graphics (i3-1115G4E)
Display Mode	1 x DP/HDMI Combo connector(auto detect)
Support Resolution	Up to 7680 x 4320 for DP 1.4a @ 60Hz Up to 4096 x 2304 for HDMI 2.0b @ 60Hz Up to 4096 x 2304 for eDP @ 60Hz
Dual Display	HDMI + DP
Super I/O	Nuvoton NPCT750
BIOS	AMI UEFI
Wake on LAN	Support wake on LAN
Storage	1 x SATAIII Connector (7Pin) 1 x M.2 M-Key(PCle x4/SATAIII Auto Detect),Support 2280 NVME SSD

Ethernet	1 x Twin RJ45 Connector Intel® i219-LM GbE LAN, support vPRO Intel® i210-AT, GbE LAN
USB	4 x USB 3.2 Gen1x1 via 2xUSB Type A Stack port 2 x Dual USB type A connector USB power control by BIOS GPIO (enable/disable)

	Without re-driver IC 1 x USB 2.0 via 180° Pitch 2.0mm 2x5Pin DIP type header 2 USB2.0 signal 1 x SATA 3.0 connector: Data transfer rate up to 6Gb/s 1 x SATA power connector :90° pitch 2.0mm 2x5 pin male header
--	---

Serial	1 x DB9 Male Connector																																																		
	<ul style="list-style-type: none"> ✓ 1x RS232 port, Pin1 w/5V/12V/RTS select (COM1) ✓ 1x RS232/RS422/RS485 port (COM2) 																																																		
																																																			
	<table border="1"> <thead> <tr> <th>Pin#</th> <th>COM1(RS232)</th> <th>COM2(RS232)</th> <th>COM2(RS422)</th> <th>COM2(RS485)</th> </tr> </thead> <tbody> <tr> <td>1</td> <td>RTS/5V/12V</td> <td></td> <td></td> <td></td> </tr> <tr> <td>2</td> <td>RX</td> <td></td> <td></td> <td></td> </tr> <tr> <td>3</td> <td>TX</td> <td></td> <td></td> <td></td> </tr> <tr> <td>4</td> <td>CTS</td> <td></td> <td></td> <td></td> </tr> <tr> <td>5</td> <td colspan="4" style="text-align: center;">GND</td> </tr> <tr> <td>6</td> <td></td> <td>TX</td> <td>RX+</td> <td></td> </tr> <tr> <td>7</td> <td></td> <td></td> <td>RX-</td> <td></td> </tr> <tr> <td>8</td> <td></td> <td></td> <td>TX-</td> <td>D-</td> </tr> <tr> <td>9</td> <td></td> <td>RX</td> <td>TX+</td> <td>D+</td> </tr> </tbody> </table>	Pin#	COM1(RS232)	COM2(RS232)	COM2(RS422)	COM2(RS485)	1	RTS/5V/12V				2	RX				3	TX				4	CTS				5	GND				6		TX	RX+		7			RX-		8			TX-	D-	9		RX	TX+	D+
Pin#	COM1(RS232)	COM2(RS232)	COM2(RS422)	COM2(RS485)																																															
1	RTS/5V/12V																																																		
2	RX																																																		
3	TX																																																		
4	CTS																																																		
5	GND																																																		
6		TX	RX+																																																
7			RX-																																																
8			TX-	D-																																															
9		RX	TX+	D+																																															

Digital I/O	8-bit digital I/O with 5V/12V selectable via jumper, via 180° pitch 2.0mm 2x5pin male header 4-bit digital Input 4-bit digital Output
--------------------	---

RTC Battery	Support RTC CR2477 battery via 180° pitch 1.25mm 2-pin wafer
--------------------	--

Smart battery	Support 3S1P 18650 battery pack *Battery power input needs to support AT/ATX power mode as well
----------------------	--

Audio	<p>1 x Line out via 3.5mm audio jack connector</p> <p>Mic-in and speaker out (support 1x2w stereo speakers) via 180° pitch 2.0mm 2x5pin male header</p>
Expansion Bus	<p>1 x full-size mini-PCI-express slot for M-PCIE and USB signal</p> <p>1 x M.2 2230 E-Key slot</p> <p>1 M2 standoff</p> <p>Support PCIe x1 and USB signal</p> <p>Support Intel® CNVi module and Intel® wPro</p> <p>1 x M.2 2280 M-Key slot</p> <p>Support PCIe x1 and USB signal</p> <p>Support 1 clamshell nano-SIM slot</p> <p>1 x Nano SIM slot via onboard micro SD+ Nano SIM combo slot for mini-PCle</p>
Buzzer	1 x Onboard buzzer
Button	<p>1 x Power Button via pitch 2.5mm 2pin terminal block and 180° pitch 2.0mm 2pin wafer</p> <p>1 x Reset Button via 180° pitch 2.0mm 2pin wafer</p>
Power Management	<p>1 x Power connector</p> <p>DC 9~36V power range</p>
Switches and LED Indicators	<p>1 x Power on/off switch (BT1/CN2/CN3)</p> <p>1 x Ambient light sensor for auto dimming support via 180° pitch 1.25mm 2pin wafer</p> <p>1 x HDD LED status</p> <p>1 x Power LED status</p>
Signals to LCD	<p>LVDS(default) eDP(option)</p> <p>LVDS and eDP are selectable via BOM control, support LCD parameter auto detection</p> <p>Backlight Control & Power, support auto dimming</p> <p>1xUSB2.0 for PCAP touch screen</p>
Backlight	1 x 180° pitch 2.0mm 6pin wafer for high brightness backlight control and power, support auto dimming

External I/O port	1 x COM Ports (COM1-1/COM1-2) 4 x USB 3.2 Gen1 Ports (stack) 2 x RJ45 GbE LAN Ports 1 x DP Port 1 x Audio Jack (Line out)
TPM	TPM 2.0 via SPI interface TPM 2.0 solution *Note: Only support Windows 10 IOT
Temperature	Operating: -20°C to 60°C Storage: -40°C to 80°C
Humidity	10% - 95%, non-condensing, operating
Watchdog Timer	255 levels
EMI/EMS	Meet CE/FCC class A
OS Support	Windows 10, Windows 11 Linux Ubuntu 20.04 and above

2.2 Board Overview

2.2.1 Board Top View

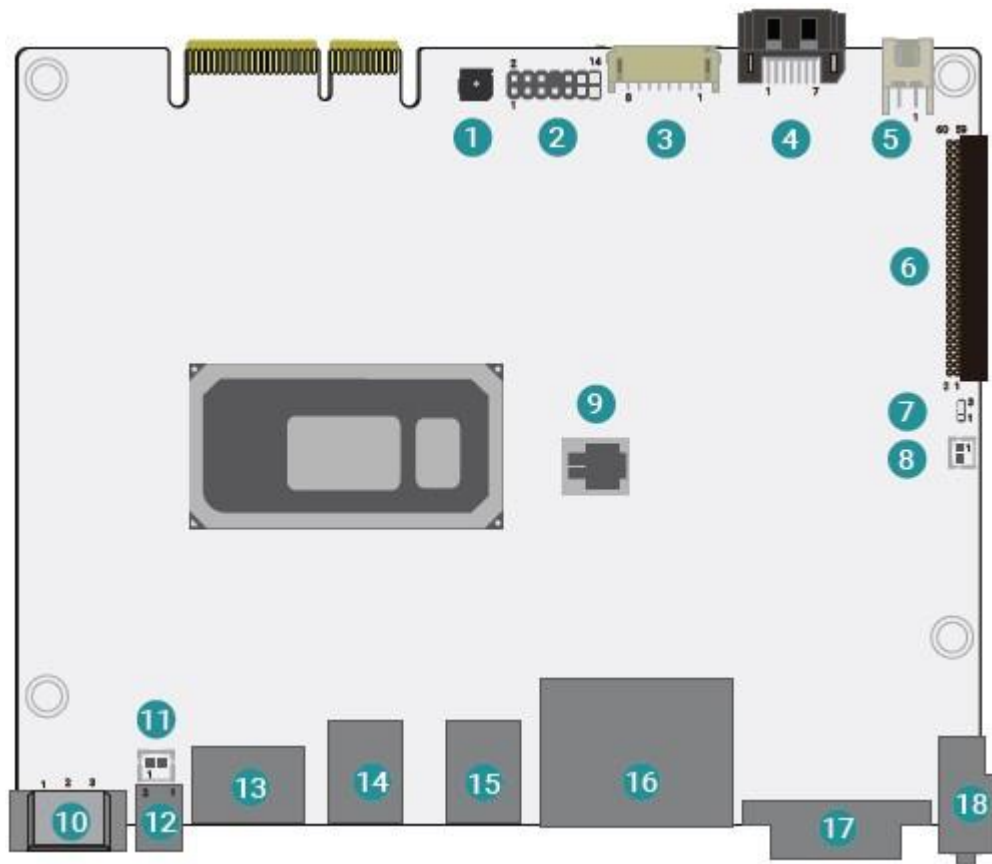

(units :mm)

1	Buzzer	10	DC IN Header
2	ESPI Header	11	Reset Button
3	Battery Header	12	Power Button
4	SATA0	13	DP/HDMI
5	SATA Power	14	▲ USB2_3/4
6	2x30 Pin Header	15	▲ USB2_1/2
7	Clear CMOS		▼ USB3_1/2
8	RTC Battery	16	LAN1 & LAN2
9	SPI	17	▼ USB3_3/4 COM Port
		18	Audio

2.2.2 Board Bottom View

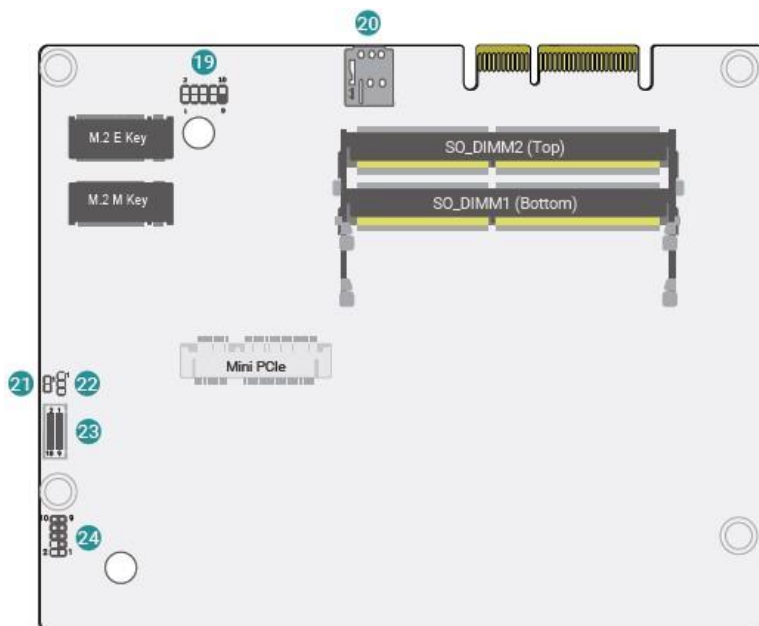

19	USB Header
20	SIM Card Slot
21	EC Debug
22	DIO Power Select (CN1_DIO)
23	DIO
24	Audio Header

2.3 Jumpers Setting and Connectors

Clear CMOS (J2)

DIO Power Select (JP6)

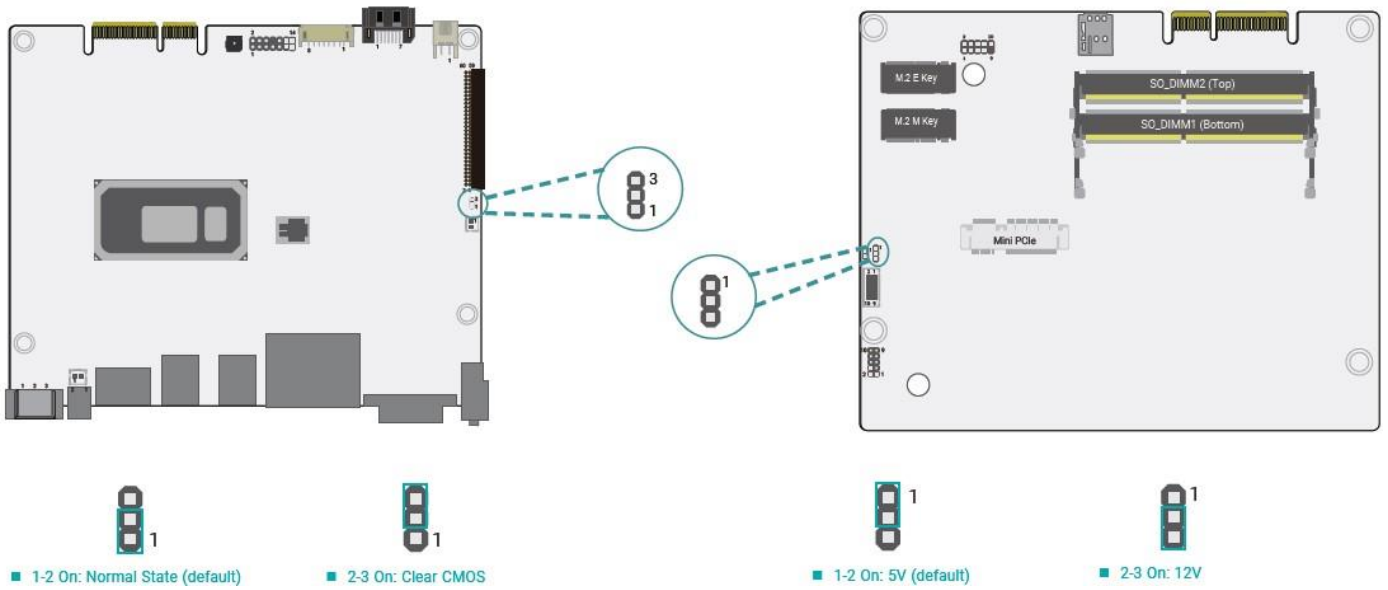

2.3.1 Pin Assignment:

SATA Power (J45)

Reset Button (J44)

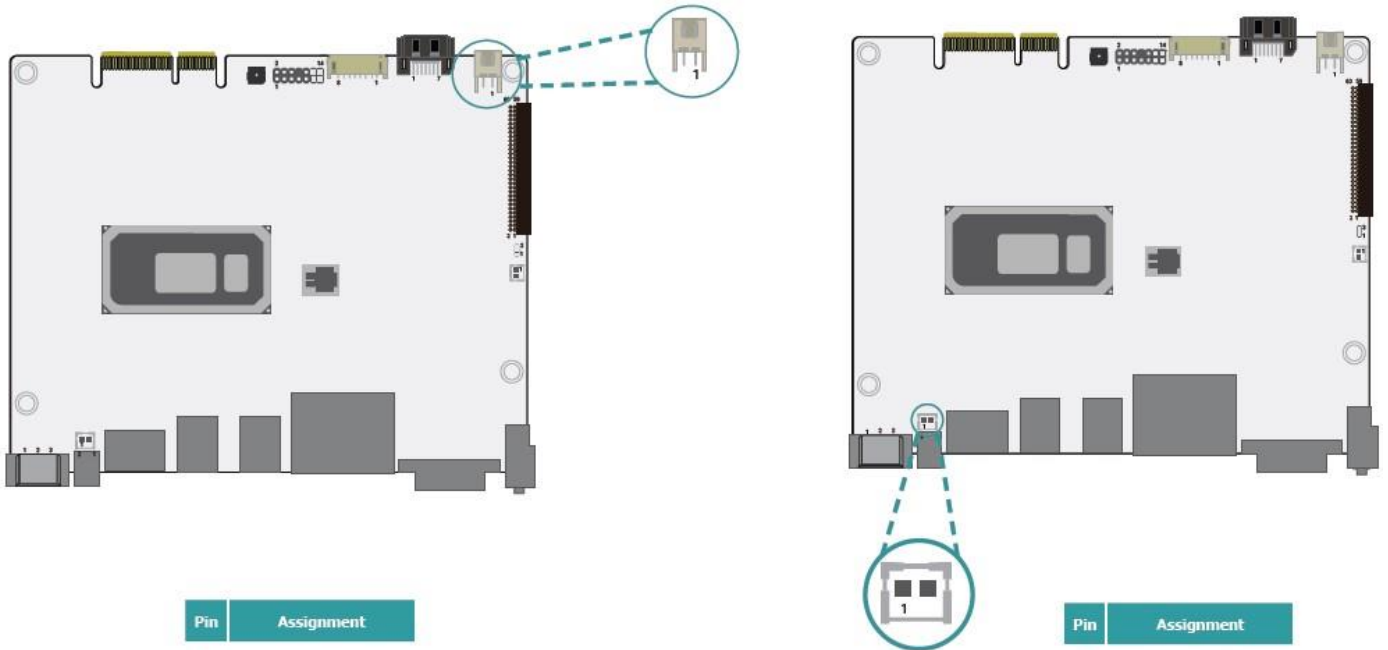

Pin	Assignment
1	GND
2	5V

Pin	Assignment
1	RESET#
2	GND

Power Button (CN43)

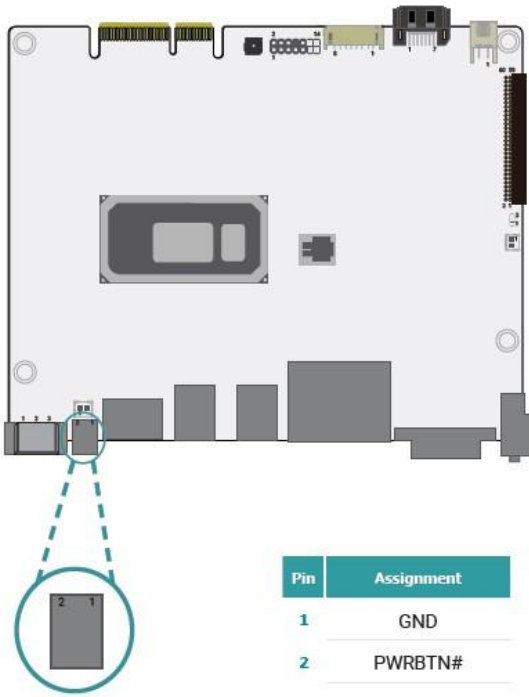

Pin	Assignment
1	GND
2	PWRBTN#

DC IN Header (CN21)

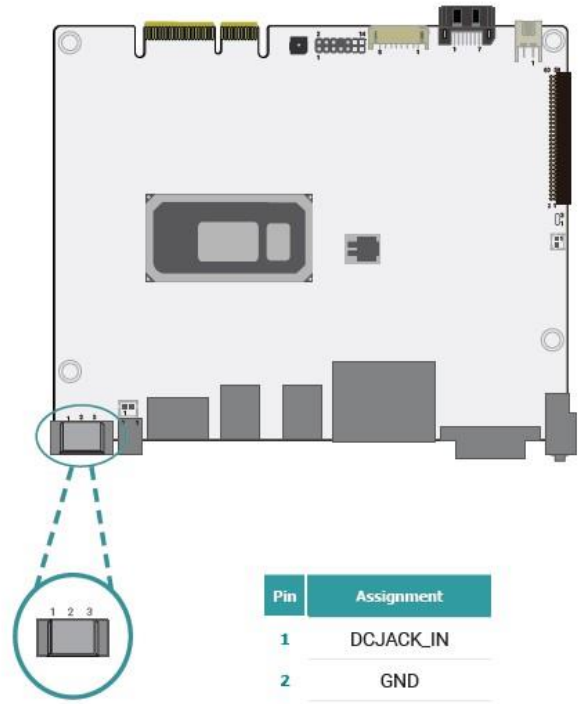

Pin	Assignment
1	DCJACK_IN
2	GND
3	NC

SATA0 (J38)

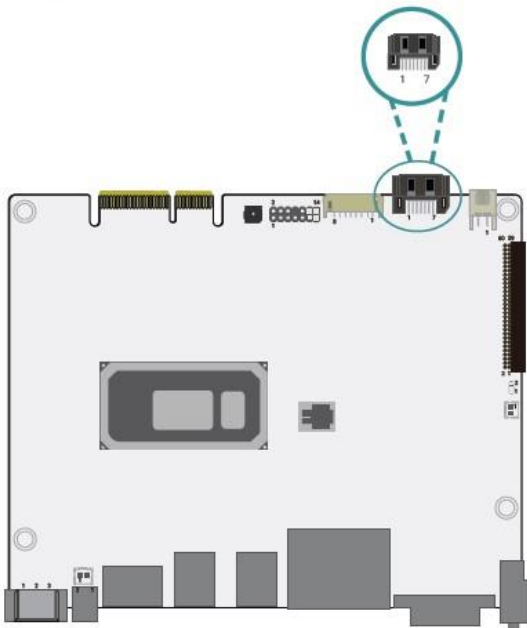

Pin	Assignment
1	GND
2	TXP
3	TXN
4	GND
5	RXN
6	RXP
7	GND

Battery Header (CN20)

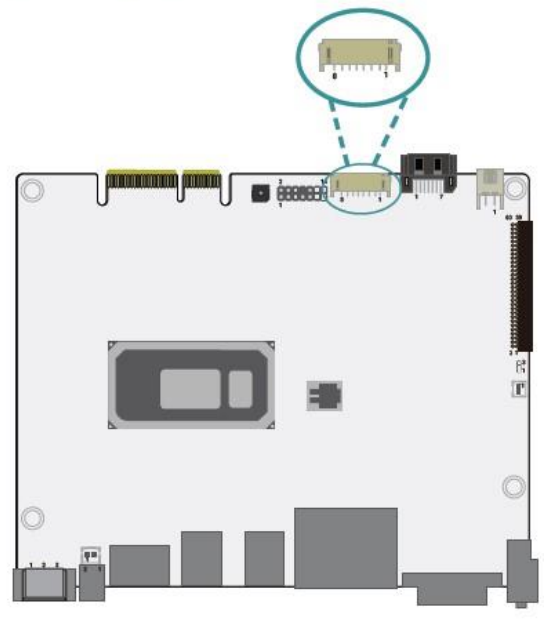

Pin	Assignment
1	+VBAT
2	+VBAT
3	SMB_DATA
4	SMB_CLK
5	NC
6	GND
7	GND
8	BAT_ON

COM Port (URCN1)

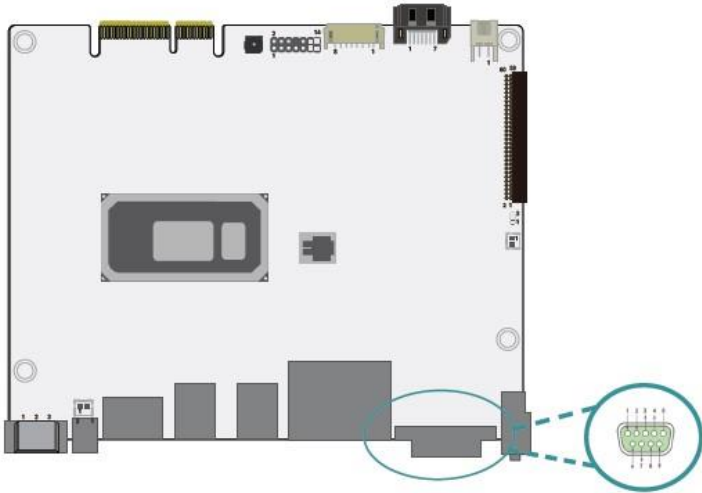

Pin	COM2 (RS232)	COM2 (RS422)	COM2 (RS485)
1	12V/5V/RTS1	12V/5V/RTS1	12V/5V/RTS1
2	RXD1	RXD1	RXD1
3	TXD1	TXD1	TXD1
4	CTS1	CTS1	CTS1
5		GND	
6	TXD2	RX+	NC
7	NC	RX-	NC
8	NC	TX-	DATA-
9	RXD2	TX+	DATA+

ESPI (J18)

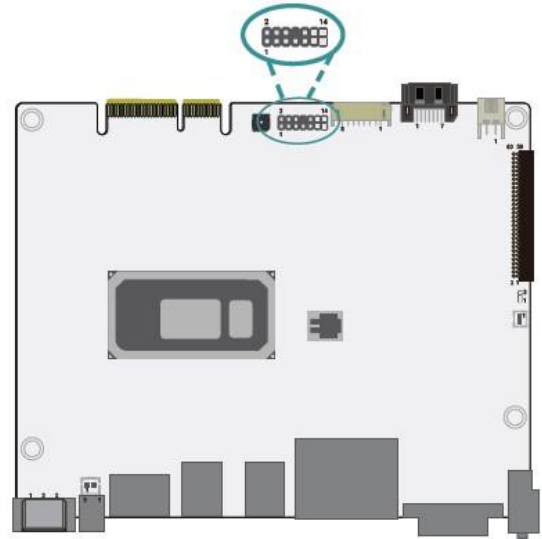

Pin	Assignment	Pin	Assignment
1	3V3SB	2	ESPI_CLK
3	ESPI_RESET#	4	GND
5	ESPI_ALT#	6	GND
7	ESPI_D0	8	---
9	ESPI_D1	10	ESPI_CS
11	ESPI_D2	12	3V3SB
13	ESPI_D3	14	3V3SB

TB-528 2x30 Pin Header (J41)

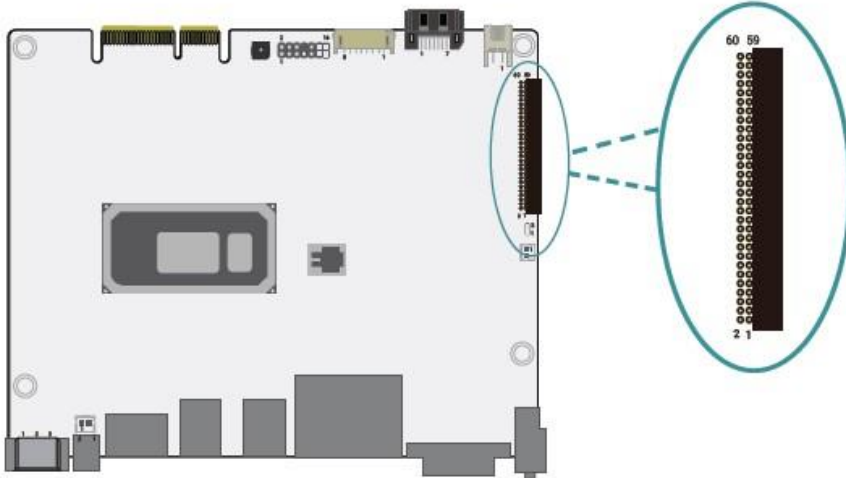

Pin	Assignment	Pin	Assignment
1	+12V	2	+12V
3	3V3SB	4	3V3SB
5	EX_PWRBTN-	6	3V3SB
7	GND	8	SRCLKREQ6#
9	SMB_DATA_MAIN	10	SMB_CLK_MAIN
11	BUF_PLT_RST-	12	PCIE_WAKE_SLOT
13	CLKOUT_PCIE_6_P	14	CLKOUT_PCIE_6_N
15	GND	16	GND
17	PCIE_PRX_P6	18	PCIE_PRX_N6
19	PCIE_PTX_P6	20	PCIE_PTX_N6
21	GND	22	GND
23	GPIO4_5V	24	GPIO3_5V
25	GPIO2_5V	26	GPIO1_5V
27	CTS3-	28	DSR3-
29	RTS3-	30	DTR3-
31	RD3	32	TD3
33	DCD3-	34	RI3-
35	GND	36	GND
37	CTS4-	38	DSR4-
39	RTS4-	40	DTR4-
41	RD4	42	TD4
43	DCD4-	44	RI4-
45	SOC_SPI_MOSI_IO0	46	SOC_SPI_CS1
47	SOC_SPI_MISO_IO1	48	SOC_SPI_CLK
49	GND	50	GND
51	USB2_DP2	52	USB2_DN2
53	USB2_DP1	54	USB2_DN1
55	PSON-	56	USB2_78_OC-
57	5V5B	58	5V5B
59	5V5B	60	5V5B

DIO Header (CN1)

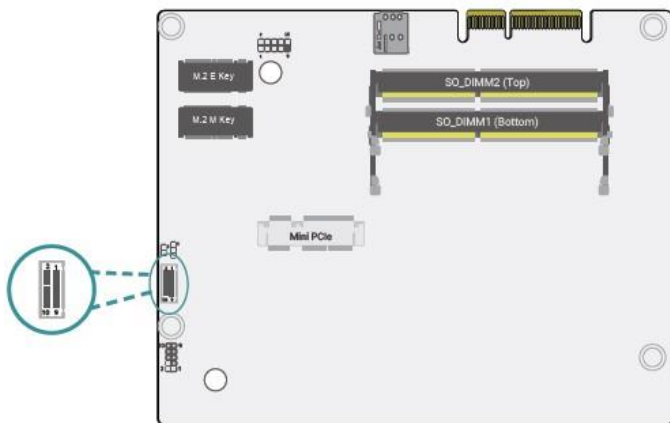

Pin	Assignment	Pin	Assignment
1	DIO_PWR	2	GND
3	DIO6	4	DIO7
5	DIO4	6	DIO5
7	DIO2	8	DIO3
9	DIO0	10	DIO1

Audio Header (AUJ1)

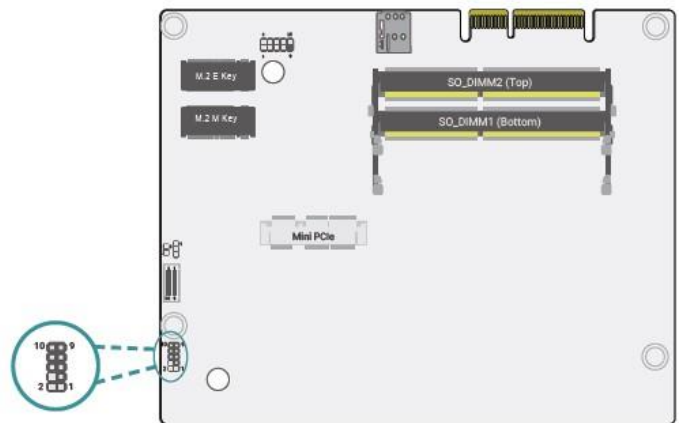

Pin	Assignment	Pin	Assignment
1	MIC-L	2	MIC_ID
3	MIC-R	4	NC
5	GND	6	GND
7	SPKOUT_R-	8	SPKOUT_L+
9	SPKOUT_R+	10	SPKOUT_L-

USB Header (UBJ1)

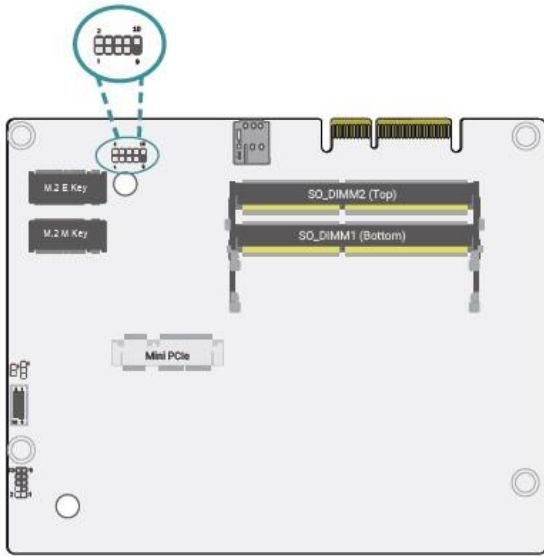

Pin	Assignment	Pin	Assignment
1	USB5V	2	USB5V
3	USB5_D-	4	USB6_D-
5	USB5_D+	6	USB6_D+
7	GND	8	GND
9	---	10	NC

EC Debug (ECJ1)

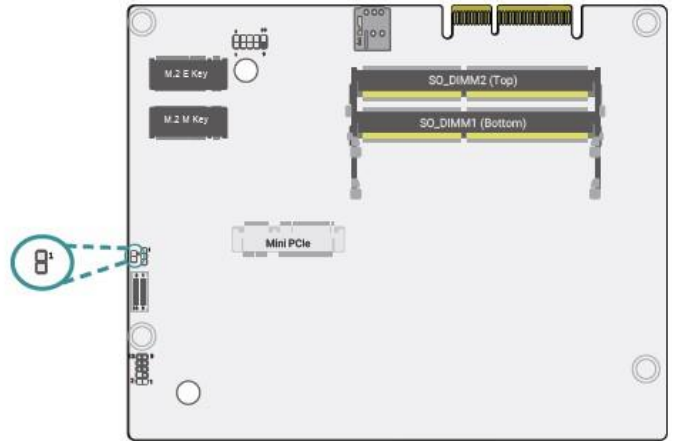

Pin	Assignment
1	SDA2
2	SCL2

2.3.2 Expansion Slot:

a) M.2 Module installation

Before installing the M.2 module into the M.2 socket, please make sure that the following safety cautions are well-attended.

1. Make sure the PC and all other peripheral devices connected to it has been powered down.
2. Disconnect all power cords and cables.
3. Locate the M.2 socket on the system board
4. Make sure the notch on card is aligned to the key on the socket.
5. Make sure the standoff screw is removed from the standoff.

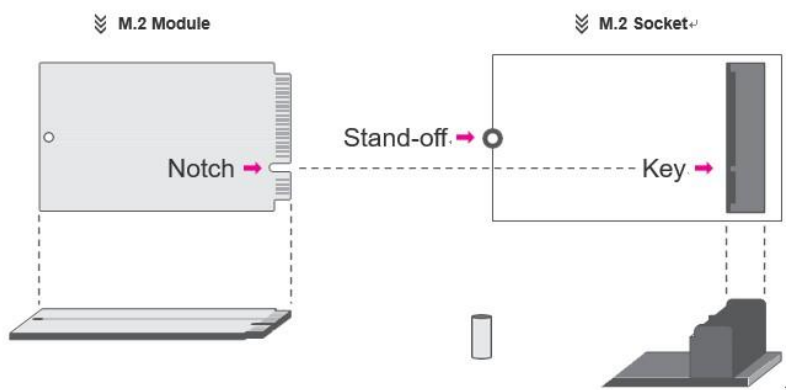

Please follow the steps below to install the card into the socket.

Step 1:

Insert the card into notch and key are

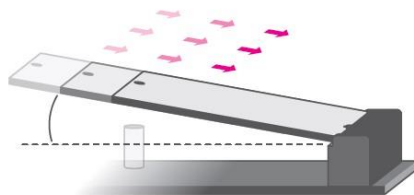

the socket at an angle while making sure the perfectly aligned.

Step 2:

Press the end of the card far from the socket down until against the stand-off.

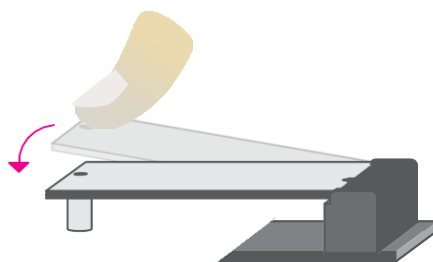

Step 3:

Screw tight the card onto the stand-off with a screw driver and a stand-off screw until the gap between the card and the stand-off closes up. The card should be lying parallel to the board when it's correctly mounted.

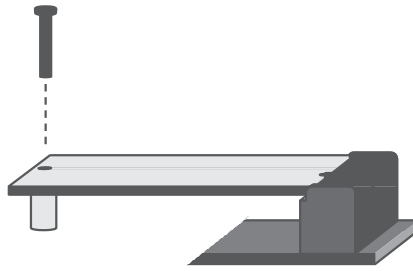

b) M-PCIe Module installation

Before installing the Mini PCIe module into the Mini PCIe socket, please make sure that the following safety cautions are well-attended.

1. Make sure the PC and all other peripheral devices connected to it has been powered down.
2. Disconnect all power cords and cables.
3. Locate the Mini PCIe socket on the system board
4. Make sure the notch on card is aligned to the key on the socket.

Please follow the steps below to install the card into the socket.

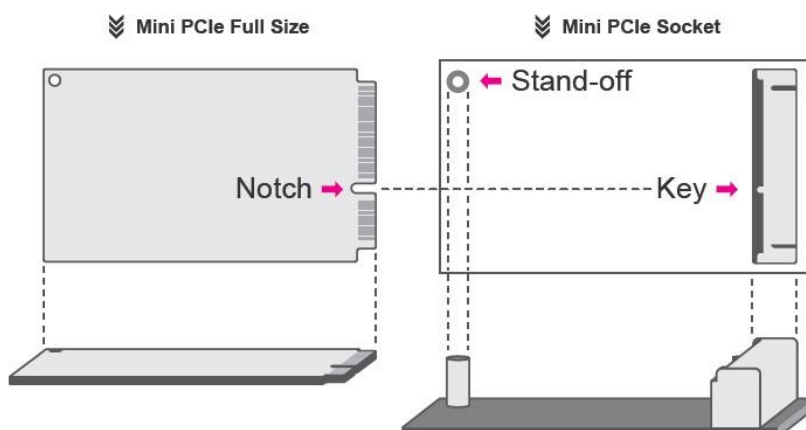

Step 1:

Insert the card into the socket at an angle while making sure the notch and key are perfectly aligned.

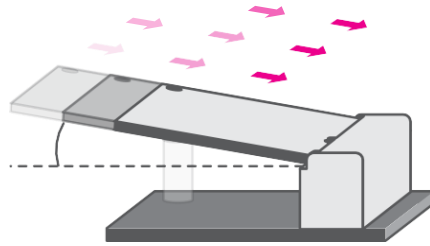

Step 2:

Press the end of the card far from the socket down until against the stand-off.

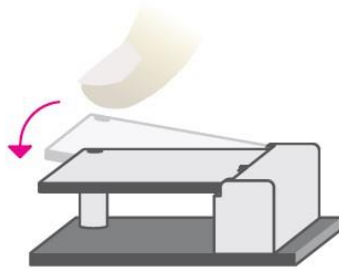

Step 3:

Screw tight the card onto the stand-off with a screw driver and a stand-off screw until the gap between the card and the stand-off closes up. The card should be lying parallel to the board when it's correctly mounted

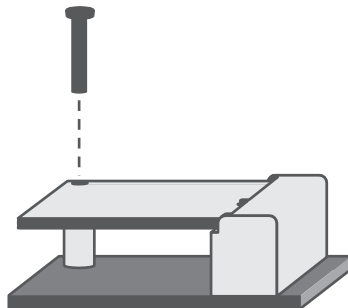

Chapter 3 BIOS Setup Description

3.1 Overview

The BIOS is a program that takes care of the basic level of communication between the CPU and peripherals. It contains codes for various advanced features found in this system board. The BIOS allows you to configure the system and save the configuration in a battery-backed CMOS so that the data retains even when the power is off. In general, the information stored in the CMOS RAM of the EEPROM will stay unchanged unless a configuration change has been made such as a hard drive replaced or a device added.

It is possible that the CMOS battery will fail causing CMOS data loss. If this happens, you need to install a new CMOS battery and reconfigure the BIOS settings.



Note:

The BIOS is constantly updated to improve the performance of the system board; therefore the BIOS screens in this chapter may not appear the same as the actual one. These screens are for reference purpose only.

Default Configuration

Most of the configuration settings are either predefined according to the Load Optimal Defaults settings which are stored in the BIOS or are automatically detected and configured without re-quiring any actions. There are a few settings that you may need to change depending on your system configuration.

Entering the BIOS Setup Utility

The BIOS Setup Utility can only be operated from the keyboard and all commands are keyboard commands. The commands are available at the right side of each setup screen.

The BIOS Setup Utility does not require an operating system to run. After you power up the system, the BIOS message appears on the screen and the memory count begins. After the memory test, the message “Press DEL to run setup” will appear on the screen. If the message disappears before you respond, restart the system or press the “Reset” button. You may also restart the system by pressing the <Ctrl> <Alt> and keys simultaneously.

Legends

Keys	Function
Right / Left arrow	Move the highlight left or right to select a menu
Up / Down arrow	Move the highlight up or down between submenus or fields

<Enter>	Enter the highlighted submenu
+ (plus key)/F6	Scroll forward through the values or options of the highlighted field
- (minus key)/F5	Scroll backward through the values or options of the highlighted field
<F1>	Display general help
<F2>	Display previous values
<F7>	Popup Boot Device List
<F9>	Optimized defaults
<F10>	Save and Exit
	Return to previous menu <Esc>

Scroll Bar

When a scroll bar appears to the right of the setup screen, it indicates that there are more available fields not shown on the screen. Use the up and down arrow keys to scroll through all the available fields.

Submenu

When “▶” appears on the left of a particular field, it indicates that a submenu which contains additional options are available for that field. To display the submenu, move the highlight to that field and press <Enter>.

3.2 Main Settings

► Main

The Main menu is the first screen that you will see when you enter the BIOS Setup Utility.



System Date

The date format is <month>, <date>, <year>. Press "Tab" to switch to the next field and press "-" or "+" to modify the value.

System Time

The time format is <hour>, <minute>, <second>. The time is based on the 24-hour military-time clock. For example, 1 p.m. is 13:00:00. Hour displays hours from 00 to 23. Minute displays minutes from 00 to 59. Second displays seconds from 00 to 59.

3.3 Advanced Settings

► Advanced

The Advanced menu allows you to configure your system for basic operation. Some entries are defaults required by the system board, while others, if enabled, will improve the performance of your system or let you set some features according to your preference.



Important:
Setting incorrect field values may cause the system to malfunction.

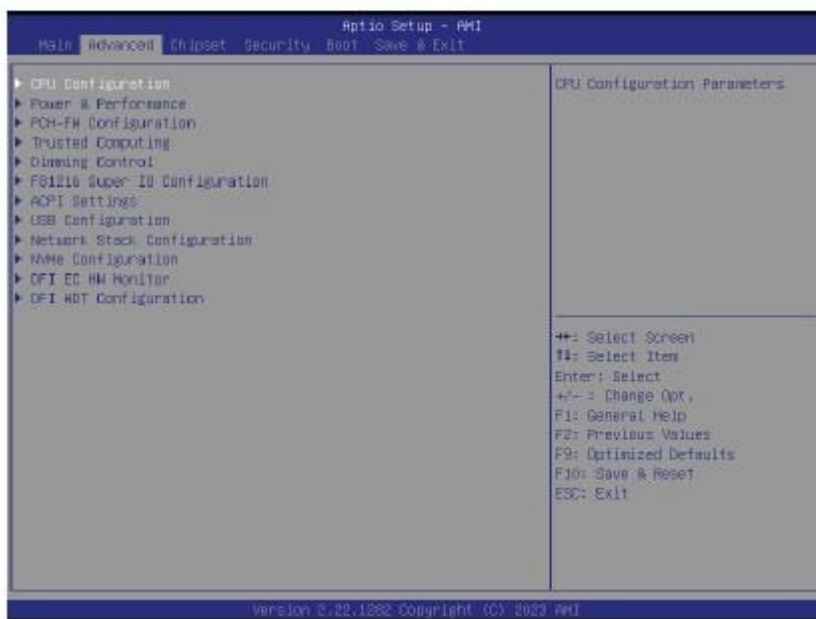

CPU Configuration

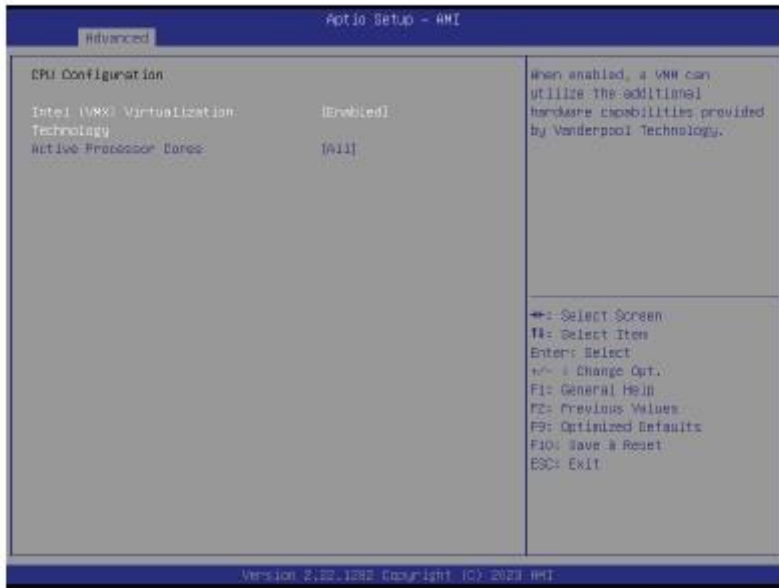

Intel (VMX) Virtualization Technology

When this field is set to Enabled, the VMM can utilize the additional hardware capabilities provided by Vanderpool Technology.

Active Processor Cores

Select number of cores to enable in each processor package: all or 1.



Note:
Some of the fields may not be available when the features are not supported by the equipped CPU.

Power & Performance



PCH-FW Configuration



ME State

When this field is set to Disabled, ME will be put into ME Temporarily Disabled Mode.

ME Unconfig on RTC Clear

When disabled, ME will not be unconfigured on RTC Clear.

Firmware Update Configuration

Configure Management Engine Technology Parameter

Trusted Computing



Security Device Support

This field is used to enable or disable BIOS support for the security device such as an TPM 2.0 to achieve hardware-level security via cryptographic keys.

Pending operation

To clear the existing TPM encryption, select "TPM Clear" and restart the system. This field is not available when "Security Device Support" is disabled.

Dimming Control



Auto Backlight Dimming

Dimming Backlight by TB573D.

F81216 Super IO Configuration

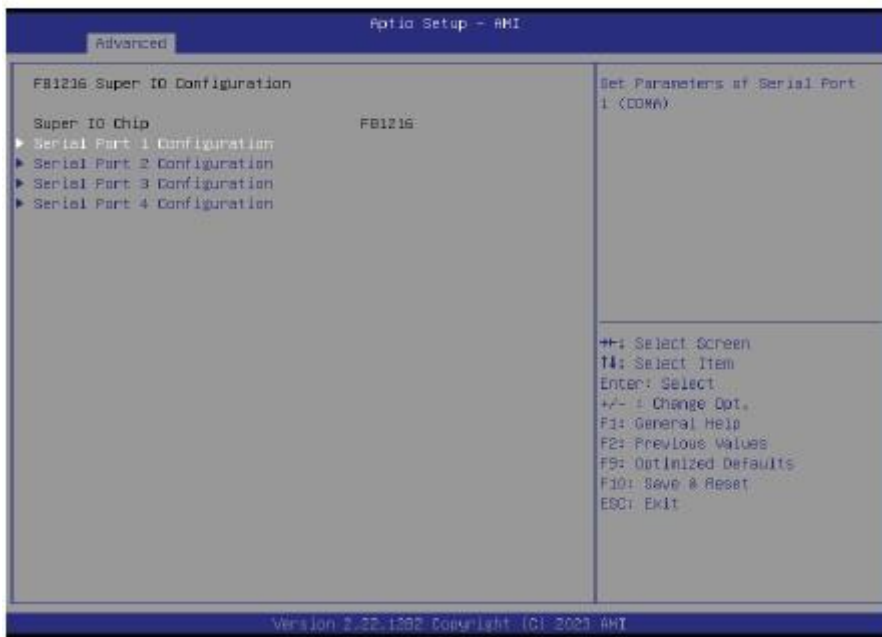

F81216 Super IO Configuration ► Serial Port 1, 2 Configuration



Serial Port

Enable or disable serial port.



Serial Port

Enable or disable serial port.

ACPI Settings



Wake system from S5 via RTC

When Enabled, the system will automatically power up at a designated time every day. Once it's switched to [Enabled], please set up the time of day – hour, minute, and second – for the system to wake up.

State After G3

Select between S0 State, and S5 State. This field is used to specify what state the system is set to return to when power is re-applied after a power failure (G3 state).

- **S0 State** The system automatically powers on after power failure.
- **S5 State** The system enter soft-off state after power failure. Power-on signal input is required to power up the system.
- **Last State** The system returns to the last state right before power failure.

USB Configuration



Legacy USB Support

- **Enabled** Enable Legacy USB support.
- **Disabled** Keep USB devices available only for EFI applications.
- **Auto** Disable Legacy support if no USB devices are connected.

XHCI Hand-off

Enable or disable XHCI Hand-off.

USB Mass Storage Driver Support

Enable or disable USB Mass Storage Driver Support.

Network Stack Configuration



Network Stack

Enable or disable UEFI network stack. The following fields will appear when this field is enabled.

IPv4 PXE Support

Enable or disable IPv4 PXE boot support. If disabled, IPv4 PXE boot support will not be available.

IPv6 PXE Support

Enable or disable IPv6 PXE boot support. If disabled, IPv6 PXE boot support will not be available.

PXE boot wait time

Set the wait time in seconds to press ESC key to abort the PXE boot. Use either +/- or numeric keys to set the value.

Media detect count

Set the number of times the presence of media will be checked. Use either +/- or numeric keys to set the value.

DFI EC HW Monitor

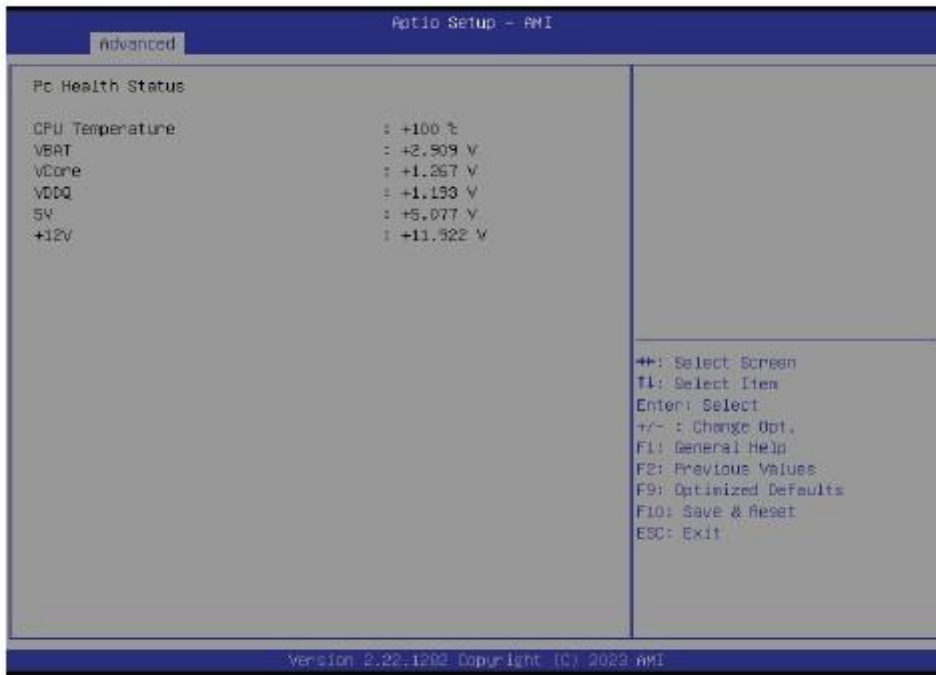

This section displays the system's health information, i.e. voltage readings, CPU and system temperatures, and fan speed readings

DFI WDT Configuration



Watchdog Timer

Enable or disable Watchdog Timer.

3.4 Chipset Settings

► Chipset



Please select a submenu and press Enter. The submenus are detailed in the following pages.

System Agent (SA) Configuration

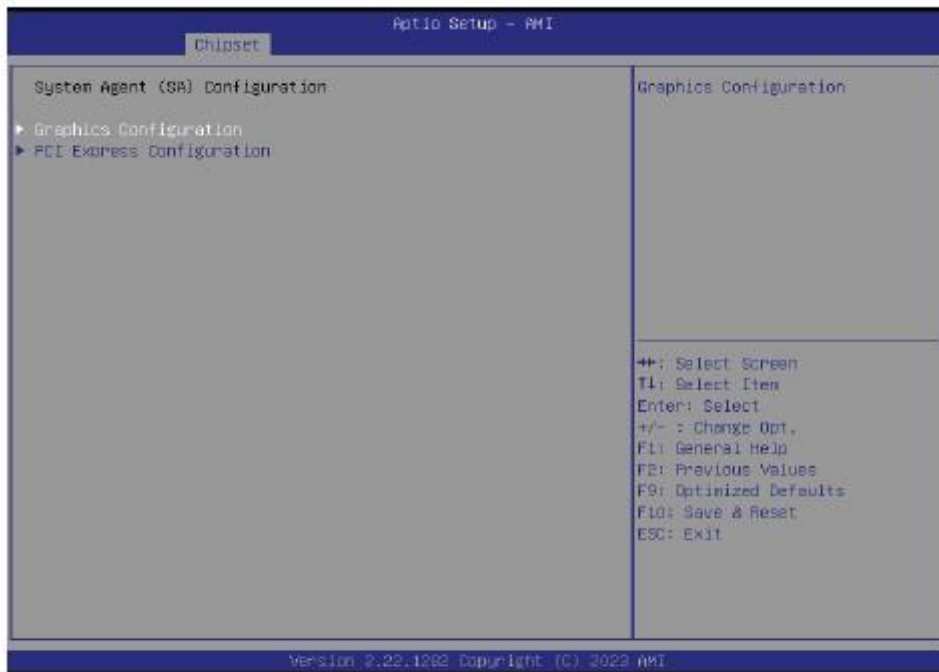

► Graphics Configuration

Graphics Configuration settings.

► PCI Express Configuration

PCI Express Configuration settings.

PCH-IO Configuration



PCI Express Configuration

PCI Express Configuration Settings

SATA Configuration

SATA Device Options Settings

HD Audio Configuration

HD Audio Subsystem Configuration Settings

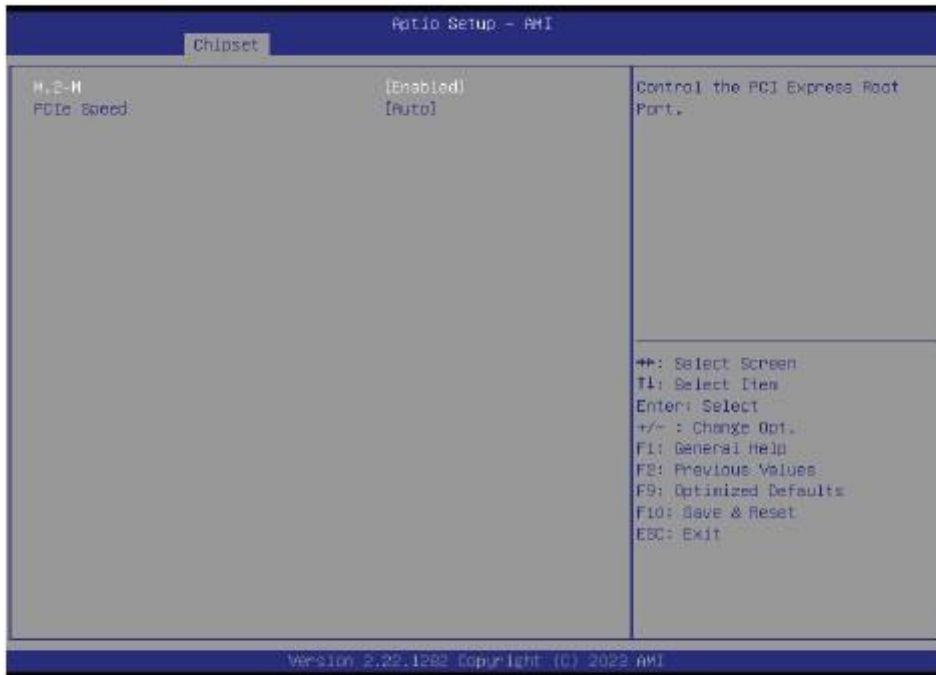

Select one of the PCI Express channels and press enter to configure the following settings.

M.2-M

Control the PCI Express Root Port.

PCIe Speed

Select PCIe Speed of the current port – AUTO, Gen1, Gen 2, or Gen3. Gen 3 is only available for the PCIe1 port. This field may not appear when the speed of the port is not configurable.



SATA Controller(s)

This field is used to enable or disable the Serial ATA controller.

SATA Speed

This field is used to select SATA speed generation limit: Auto, Gen1, Gen2 or Gen3.

Ports and Hot Plug

Enable or disable the Serial ATA port and its hot plug function.



HD Audio

Control the detection of the HD Audio device.

- **Disabled** HDA will be unconditionally disabled.
- **Enabled** HDA will be unconditionally enabled.

3.5 Security Settings

► Security

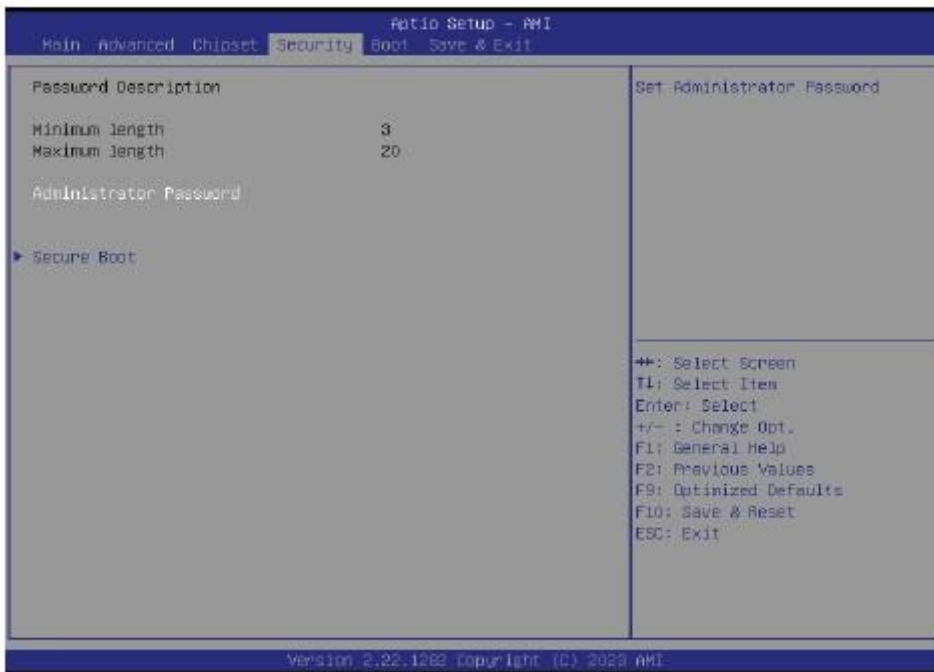

Administrator Password

Set the administrator password. To clear the password, input nothing and press enter when a new password is asked. Administrator Password will be required when entering the BIOS.

Secure Boot



Secure Boot

The Secure Boot store a database of certificates in the firmware and only allows the OSes with authorized signatures to boot on the system. To activate Secure Boot, please make sure that "Secure Boot" is "[Enabled]", Platform Key (PK) is enrolled, "System Mode" is "User", and CSM is disabled. After enabling/disabling Secure Boot, please save the configuration and restart the system. When configured and activated correctly, the Secure Boot status will be "Active".

Secure Boot Mode

Select the secure boot mode – Standard or Custom. When set to Custom, the following fields will be configurable for the user to manually modify the key database.

Restore Factory Keys

Force system to User Mode. Load OEM-defined factory defaults of keys and databases onto the Secure Boot. Press Enter and a prompt will show up for you to confirm.

Reset To Setup Mode

Clear the database from the NVRAM, including all the keys and signatures installed in the Key Management menu. Press Enter and a prompt will show up for you to confirm.

Key Management

Enables expert users to modify Secure Boot Policy variables without full authentication.

3.6 Boot Settings

▶ Boot

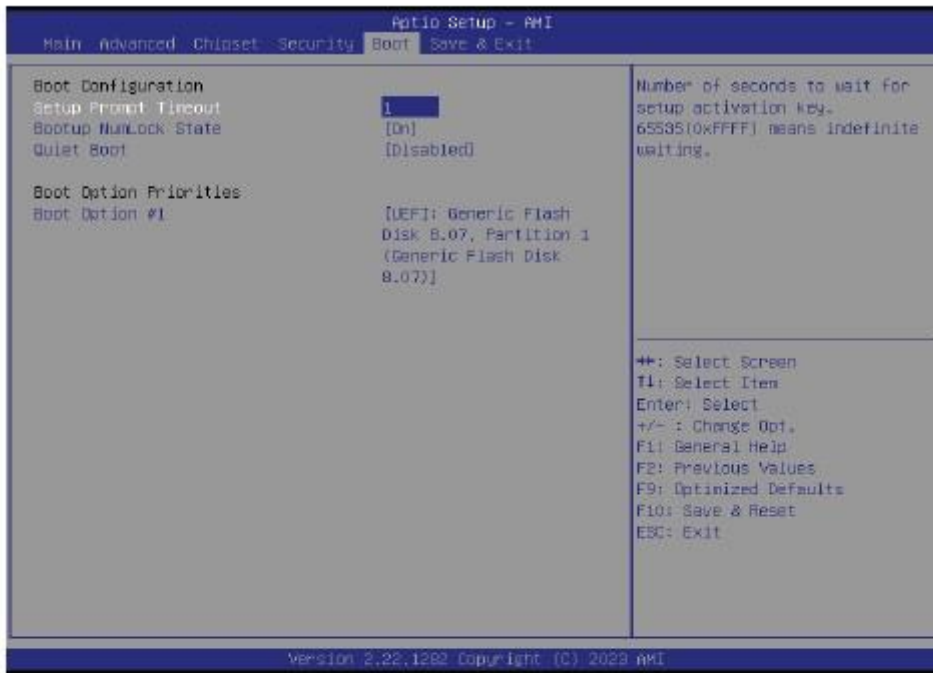

Setup Prompt Timeout

Set the number of seconds to wait for the setup activation key. 65535 (0xFFFF) denotes indefinite waiting.

Bootup NumLock State

Select the keyboard NumLock state: On or Off.

Quiet Boot

This section is used to enable or disable quiet boot option.

Boot Option Priorities

Rearrange the system boot order of available boot devices.

Fast Boot

Enable or disable fast boot.



Note:

If "Boot option filter" of "CSM Configuration" is set to "UEFI and Legacy" or "UEFI only", and "Quiet Boot" is set to enabled, "BGRT Logo" will show up for configuration. Refer to the Advanced > CSM Configuration submenu for more information.

3.7 Save & Exit Settings

► Save & Exit

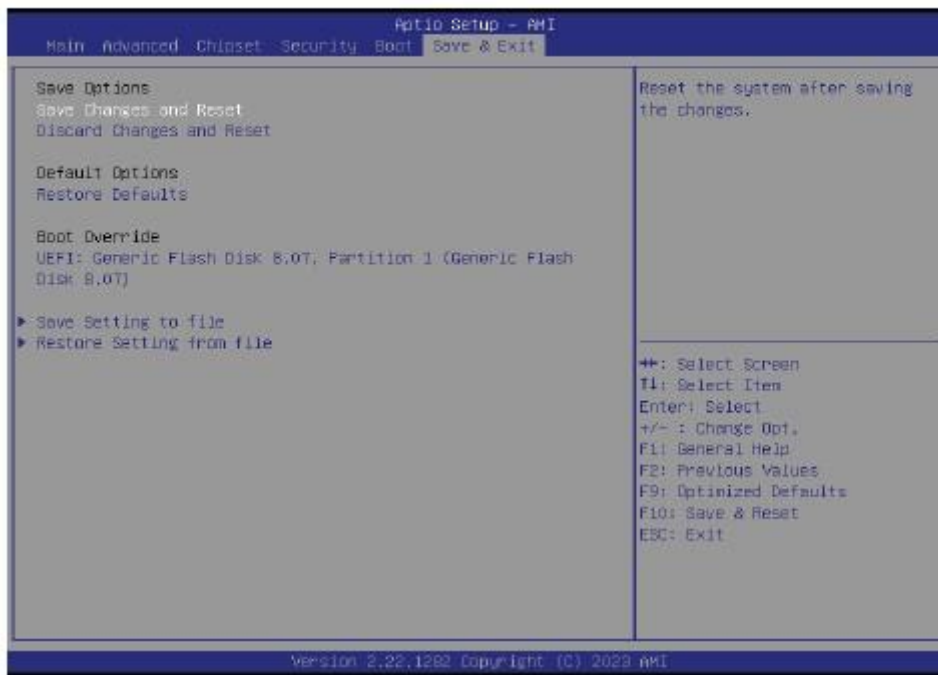

Save Changes and Reset

To save the changes, select this field and then press <Enter>. A dialog box will appear. Select Yes to reset the system after saving all changes made.

Discard Changes and Reset

To discard the changes, select this field and then press <Enter>. A dialog box will appear. Select Yes to reset the system setup without saving any changes.

Restore Defaults

To restore and load the optimized default values, select this field and then press <Enter>. A dialog box will appear. Select Yes to restore the default values of all the setup options.

Boot Override

Move the cursor to an available boot device and press Enter, and then the system will immediately boot from the selected boot device. The Boot Override function will only be effective for the current boot. The "Boot Option Priorities" configured in the Boot menu will not be changed.

- **Save Setting to file** Select this option to save BIOS configuration settings to a USB flash device.
- **Restore Setting from file** This field will appear only when a USB flash device is detected. Select this field to restore setting from the USB flash device.

► Updating the BIOS

To update the BIOS, you will need the new BIOS file and a flash utility. Please contact technical support or your sales representative for the files and specific instructions about how to update BIOS with the flash utility.

► Notice: BIOS SPI ROM

1. The Intel® Management Engine has already been integrated into this system board. Due to the safety concerns, the BIOS (SPI ROM) chip cannot be removed from this system board and used on another system board of the same model.
2. The BIOS (SPI ROM) on this system board must be the original equipment from the factory and cannot be used to replace one which has been utilized on other system boards.
3. If you do not follow the methods above, the Intel® Management Engine will not be updated and will cease to be effective.



Note:

- a. You can take advantage of flash tools to update the default configuration of the BIOS (SPI ROM) to the latest version anytime.
- b. When the BIOS IC needs to be replaced, you have to populate it properly onto the system board after the EEPROM programmer has been burned and follow the technical person's instructions to confirm that the MAC address should be burned or not.
- c. After updating unique MAC Address from manufacturing, NVM will be protected immediately after power cycle. Users cannot update NVM or MAC address.

This chapter describes the installation procedures for software and drivers under the windows 10. The software and drivers are included with the motherboard. The contents include **Intel Chipset, Graphics chipset driver, Audio driver, Intel LAN Driver, Intel® Serial I/O, Intel® Management and Security Status Installer, Intel® Management Engine Components and Intel® HID Event Filter**. The instructions are as below.

Important Note:

After installing your Windows operating system, you must install first the IntelChipset Software Installation Utility before proceeding with the installation of drivers.

4.1 Intel Chipset

To install the Intel chipset driver, please follow the steps below.

Step 1. Here is welcome page. Please make sure you save and exit all programs before install. Click **Next**.



Step 2. Read the license agreement. Click **Accept** to accept all of the terms of the license agreement.



Step 3. Click **Install** to begin the installation.

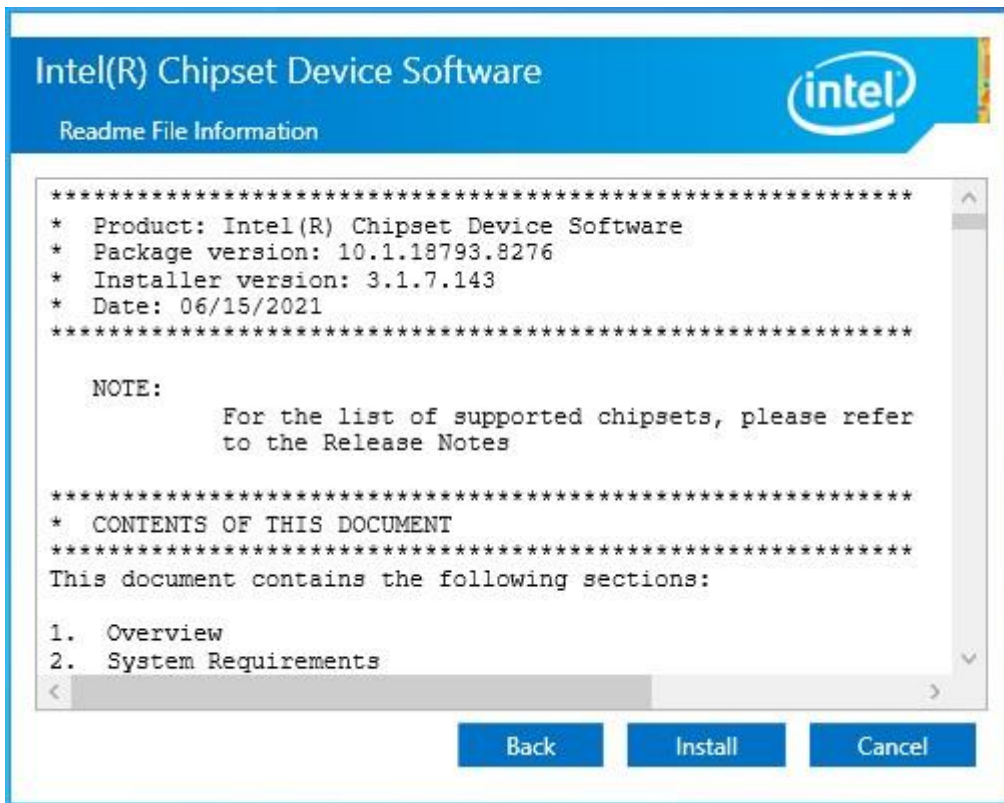

Step 4. Click **Finish** to finish installation.



4.2 Intel® HD Graphics Chipset

To install the Intel® HD Graphics Chipset, please follow the steps below.

Step 1. Click **Begin installation**.



Step 2. Read the license agreement. Click **I agree** to accept all of the terms of the license agreement.

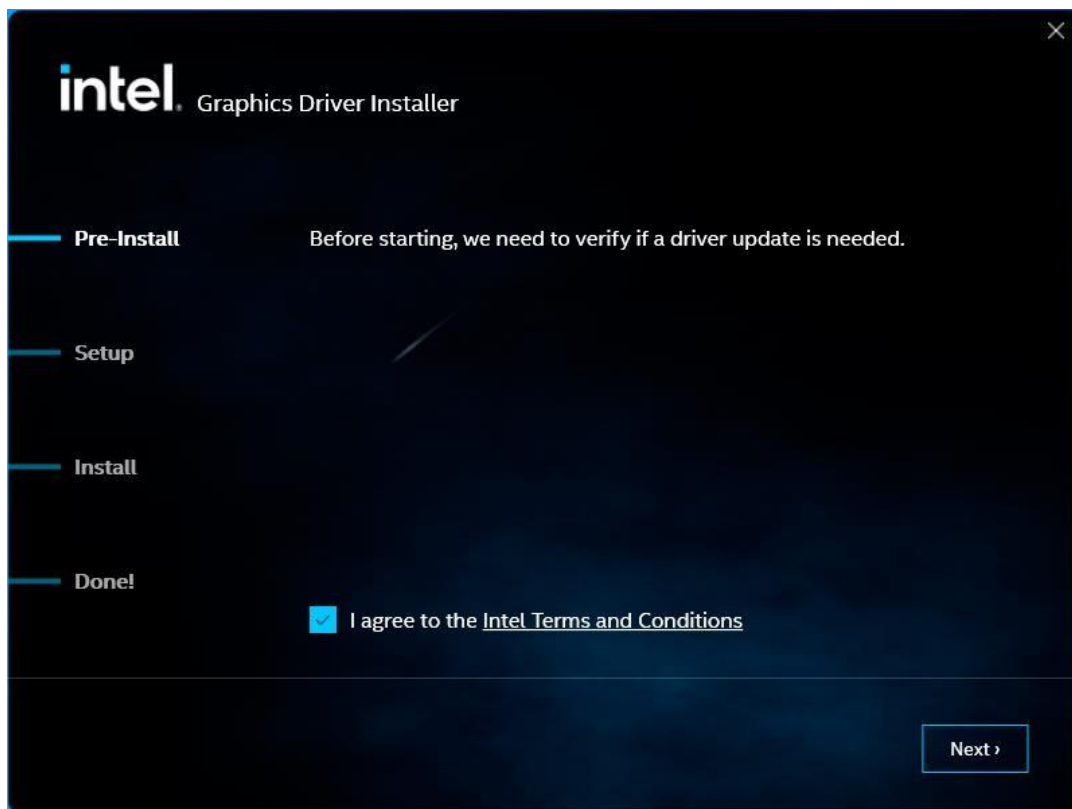

Step 3. Click **Start** to setup program.

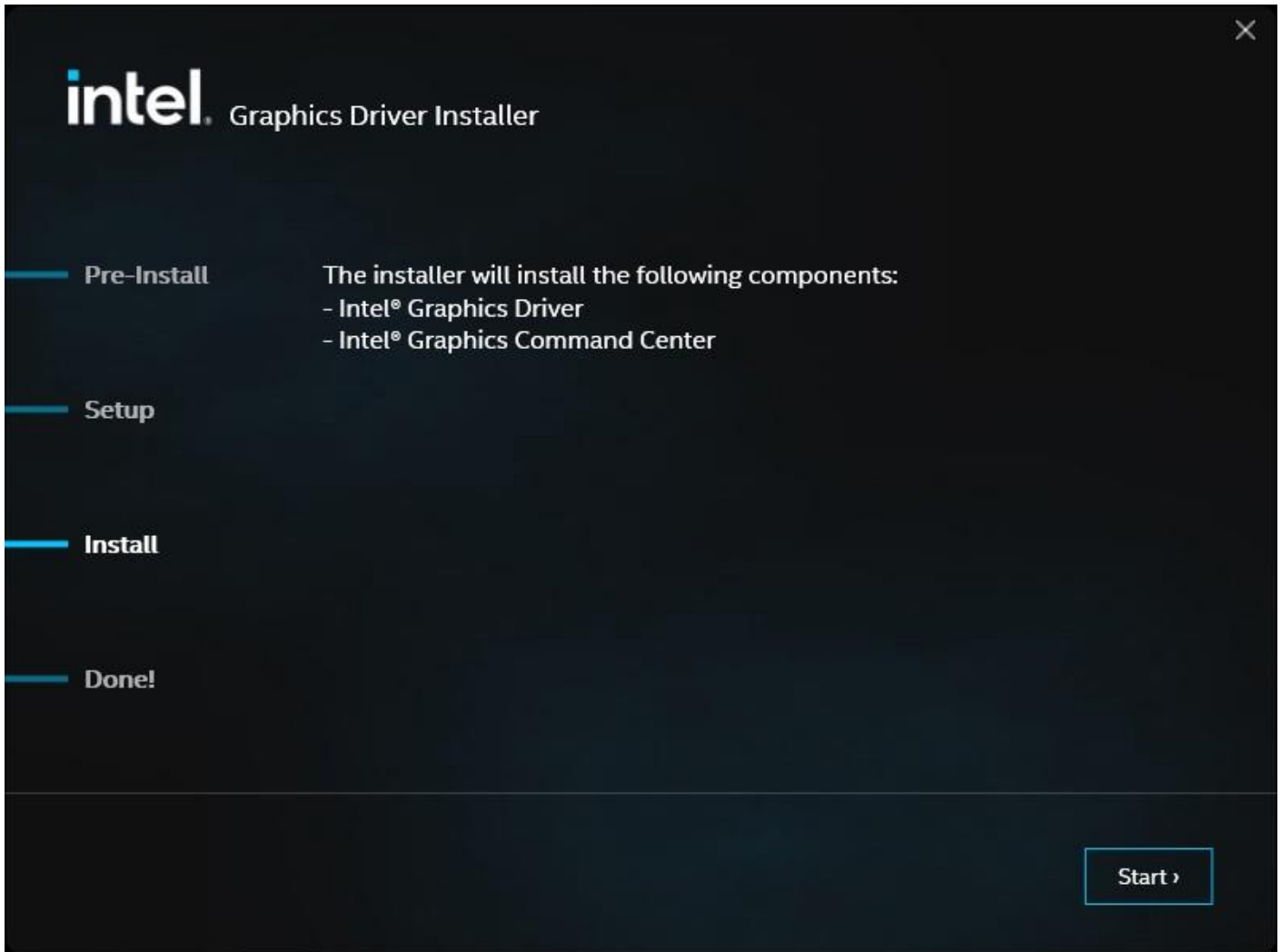

Step 4. Click **Finish** to complete installation.

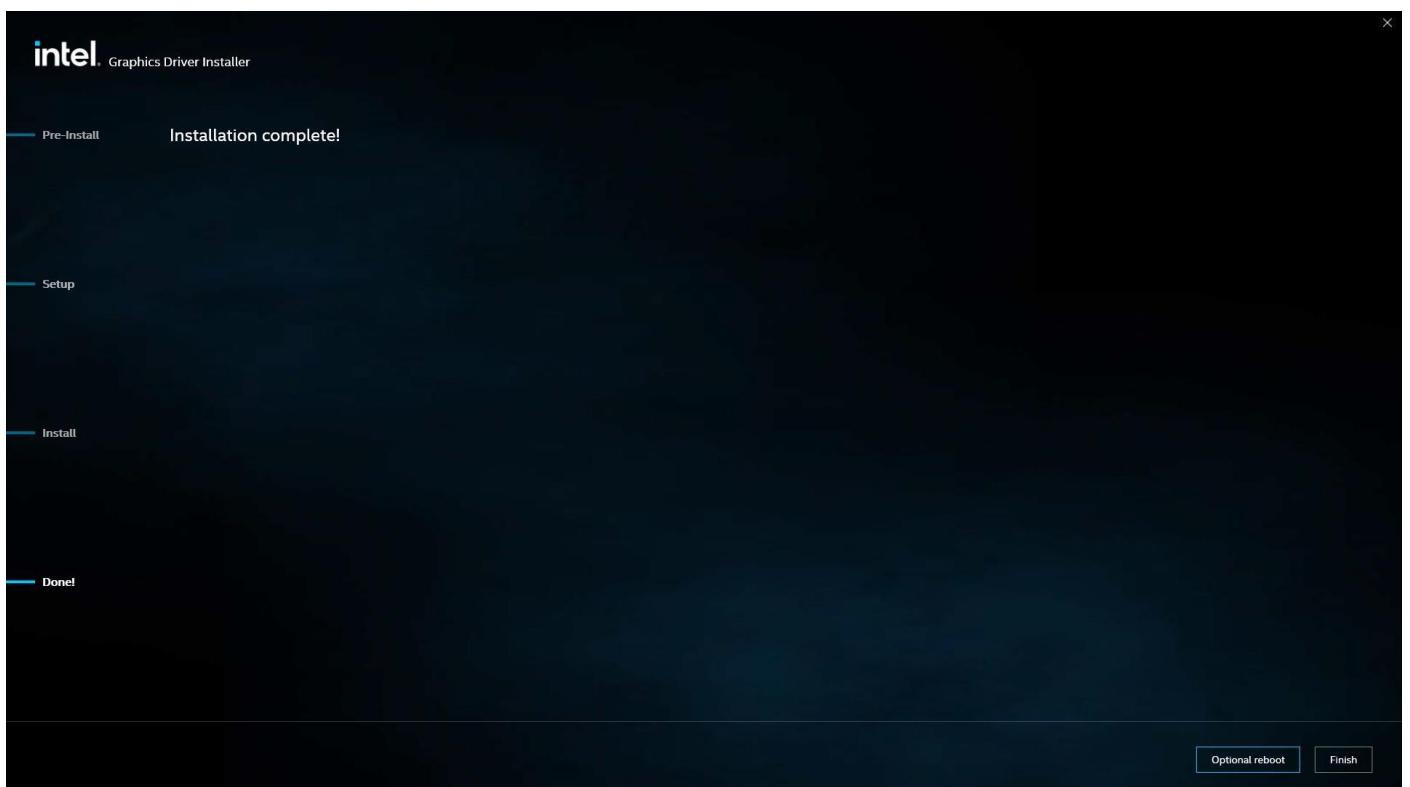

4.3 Realtek HD Audio Driver Installation

To install the Realtek HD Audio Driver, please follow the steps below.

Step 1. Click **Next** to continue.

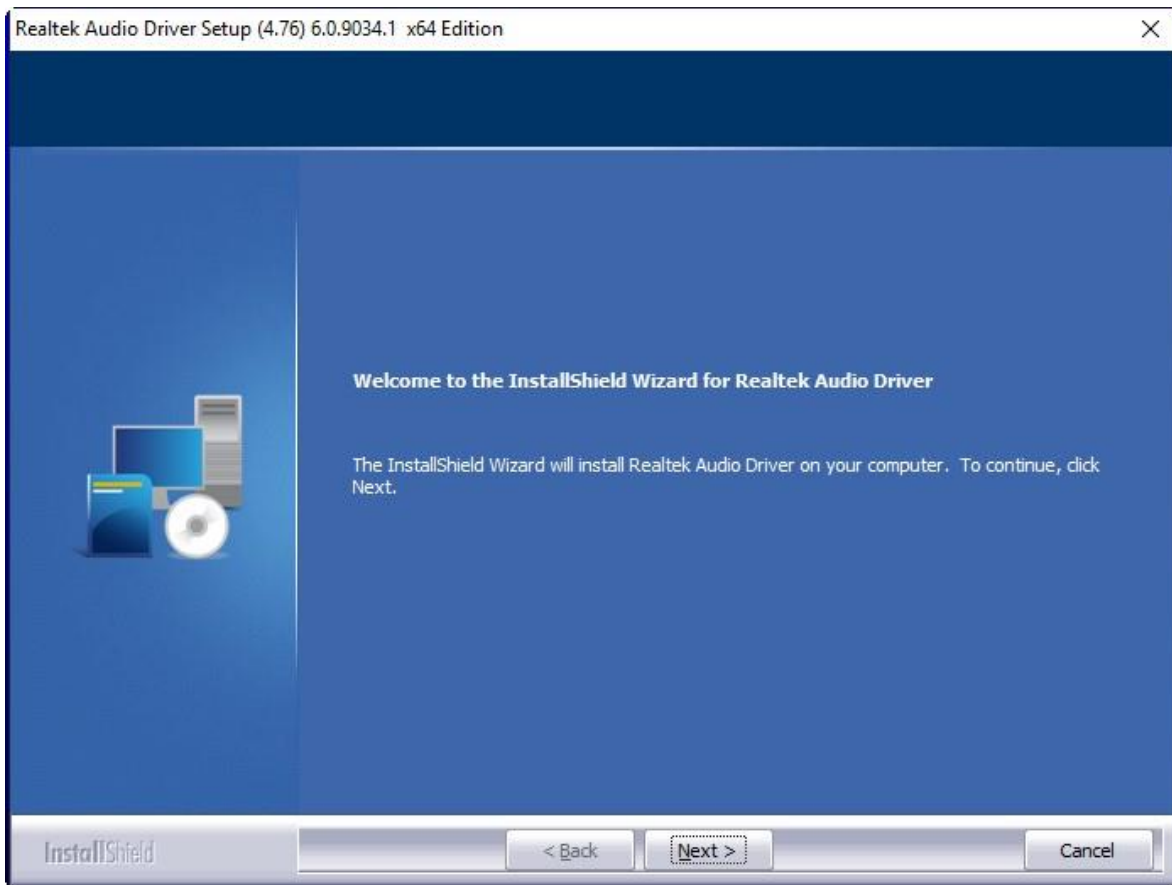

Step 2. Click **Yes, I want to restart my computer now** to complete the installation.

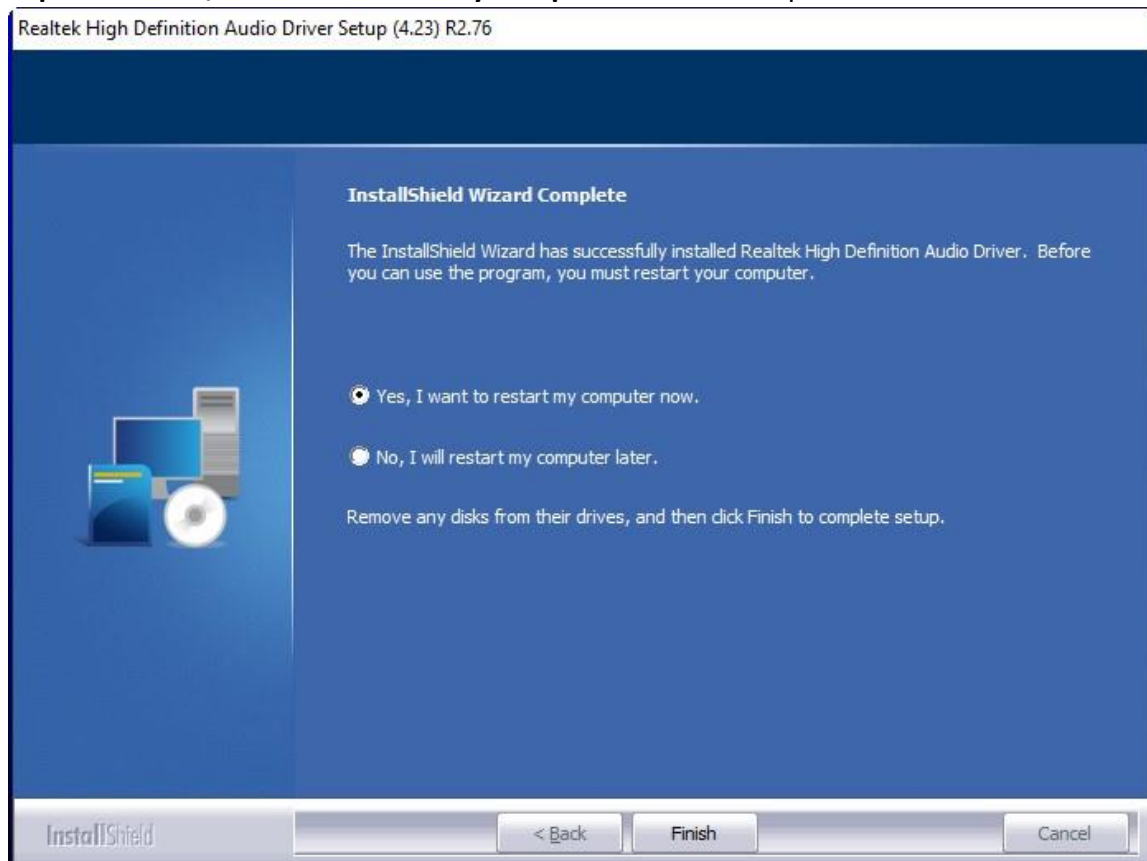

4.4 Intel LAN Driver

To install the LAN driver, please follow the steps below.

Step 1. Click **Install** to start installation.

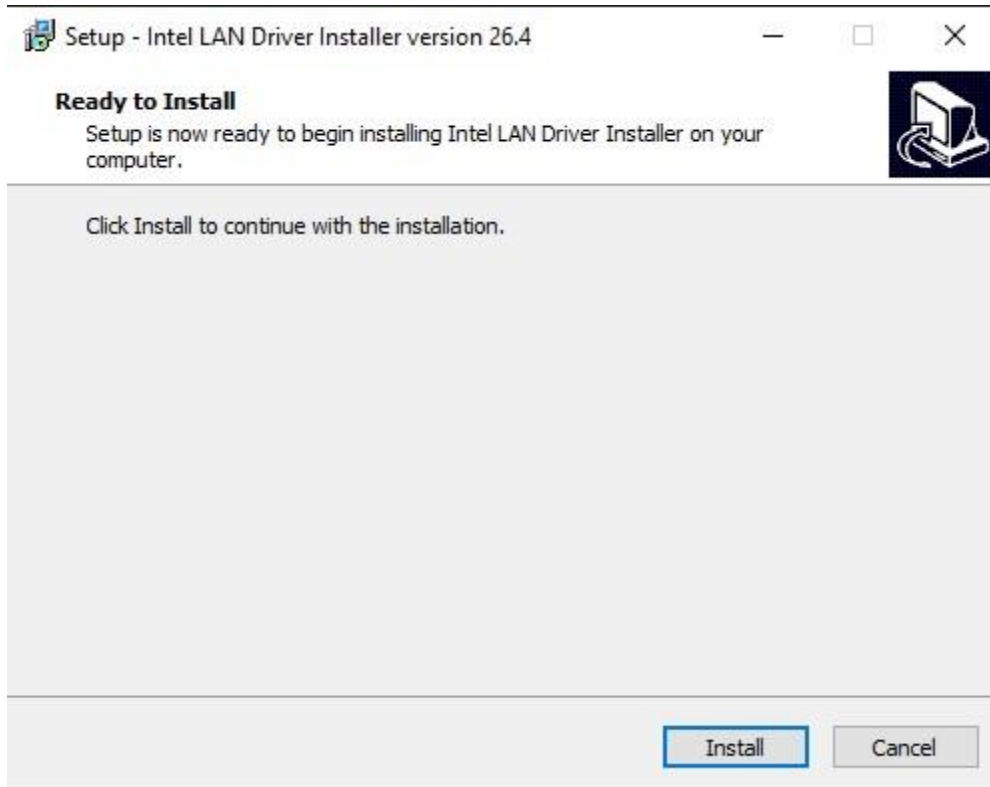

Step 2. Click **OK** to confirm the installation procedure.

Installing Drivers

Install or update drivers for Intel® Network Connections.



Step 3. Click **Close** to finish installation.



Step 4. Choose **Yes, restart the computer now** to complete the installation.



4.5 Intel® Serial I/O

To install Intel® Serial I/O, please follow the steps below.

Step 1. Click **Next** to continue.



Step 2. Choose **I accept the terms in the License Agreement** and click **Next** to begin the installation.



Step 3. Click **Next** to continue.

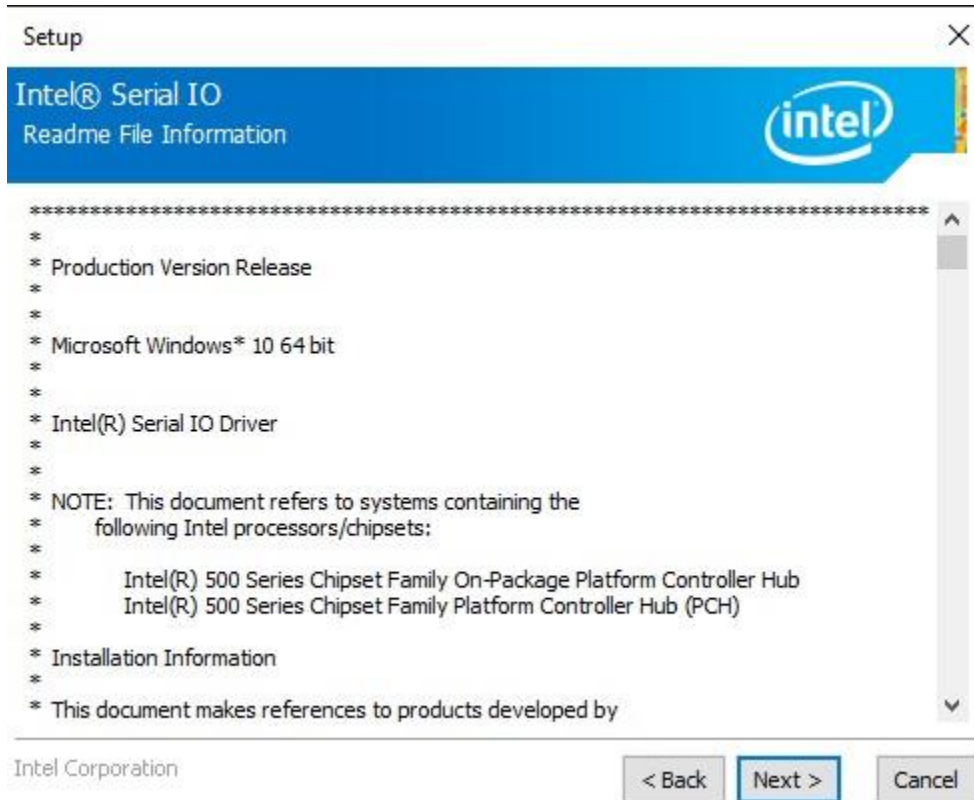

Step 4. Click **Next** to continue.

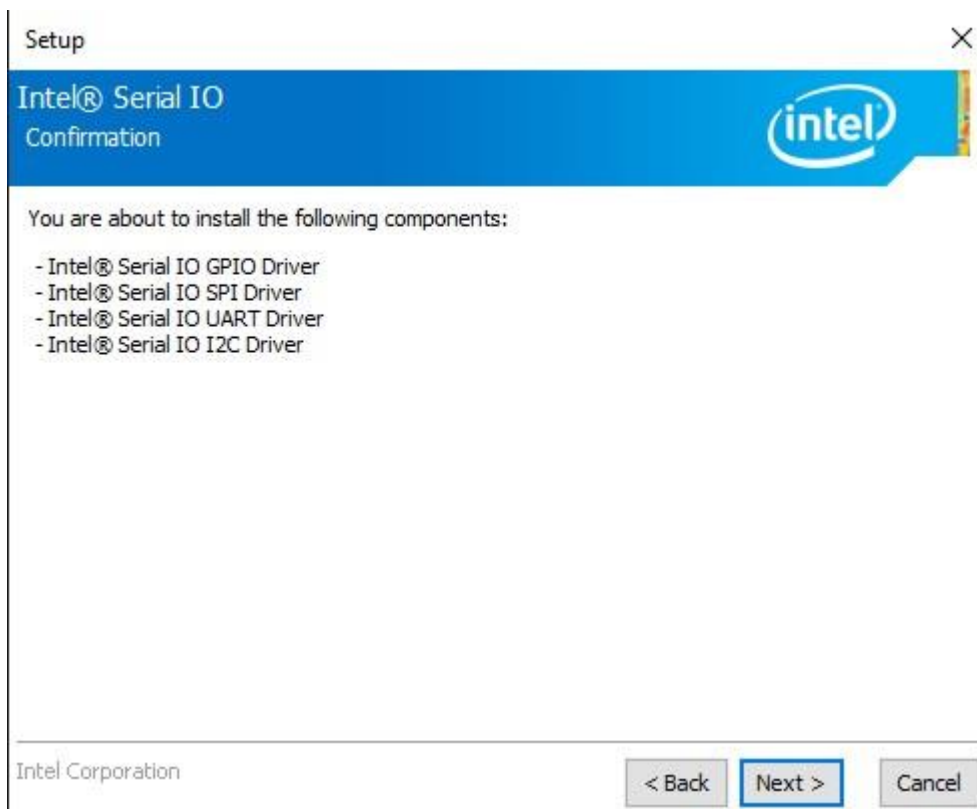

Step 5. Click **Finish** to complete installation.

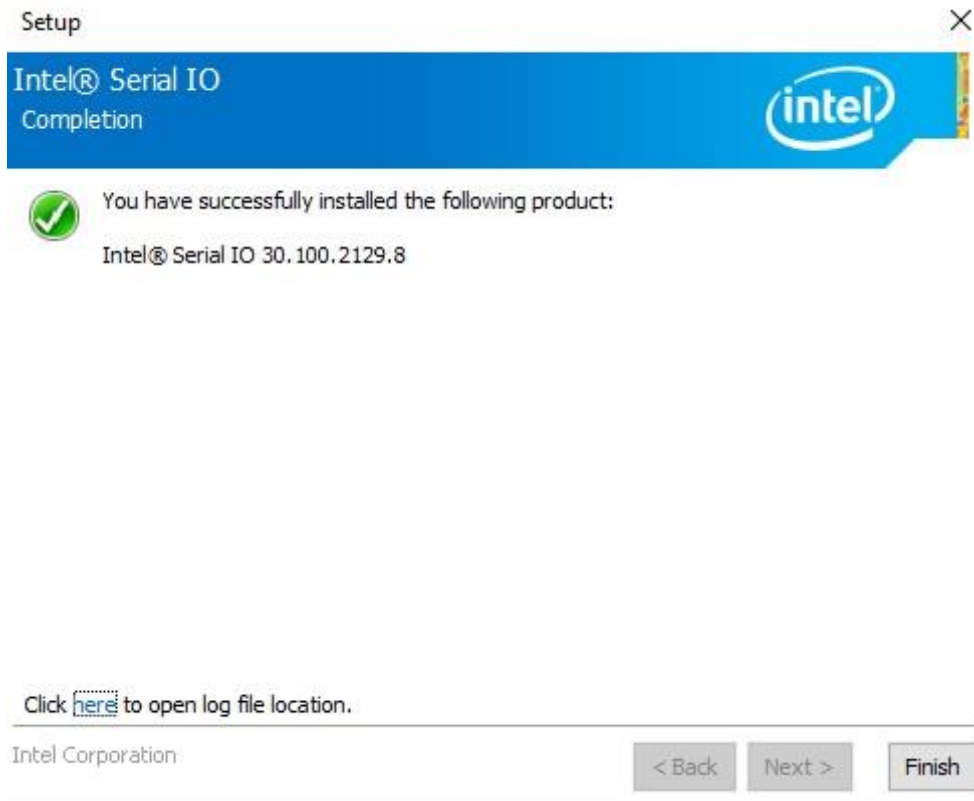

4.6 Intel® Management and Security Status Installer

Step 1. Click **Install** to continue the installation.

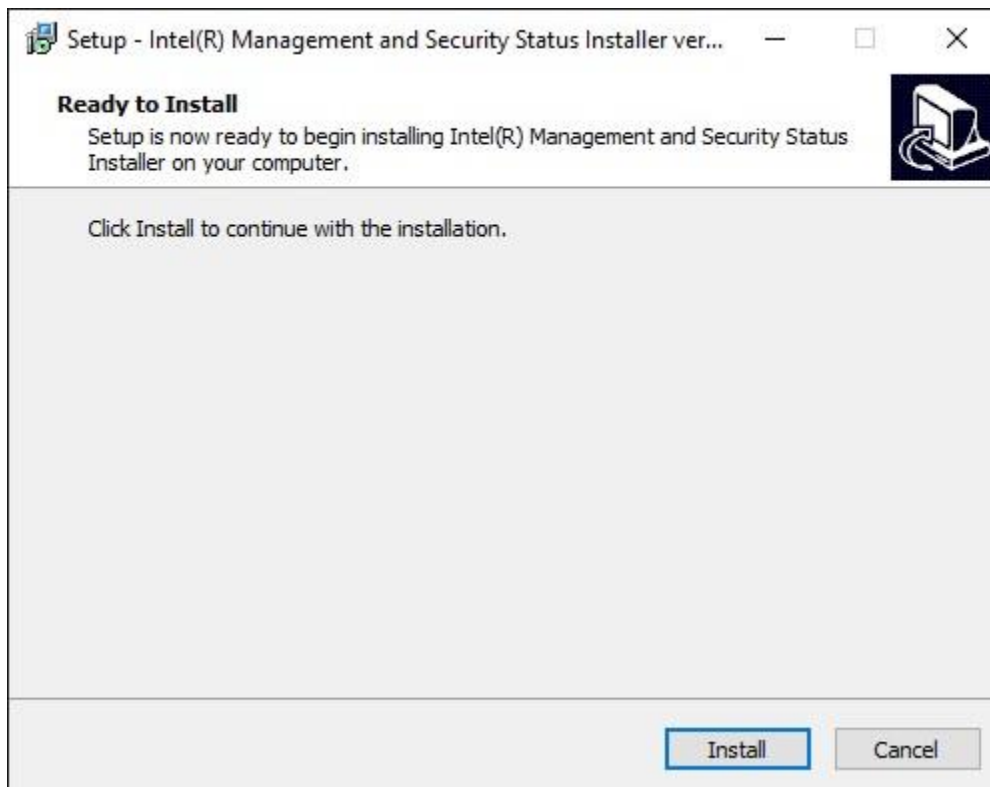

Step 2. Click **Finish** to exit setup.



4.7 Intel® Management Engine Components

Step 1. Click **Next** to continue.

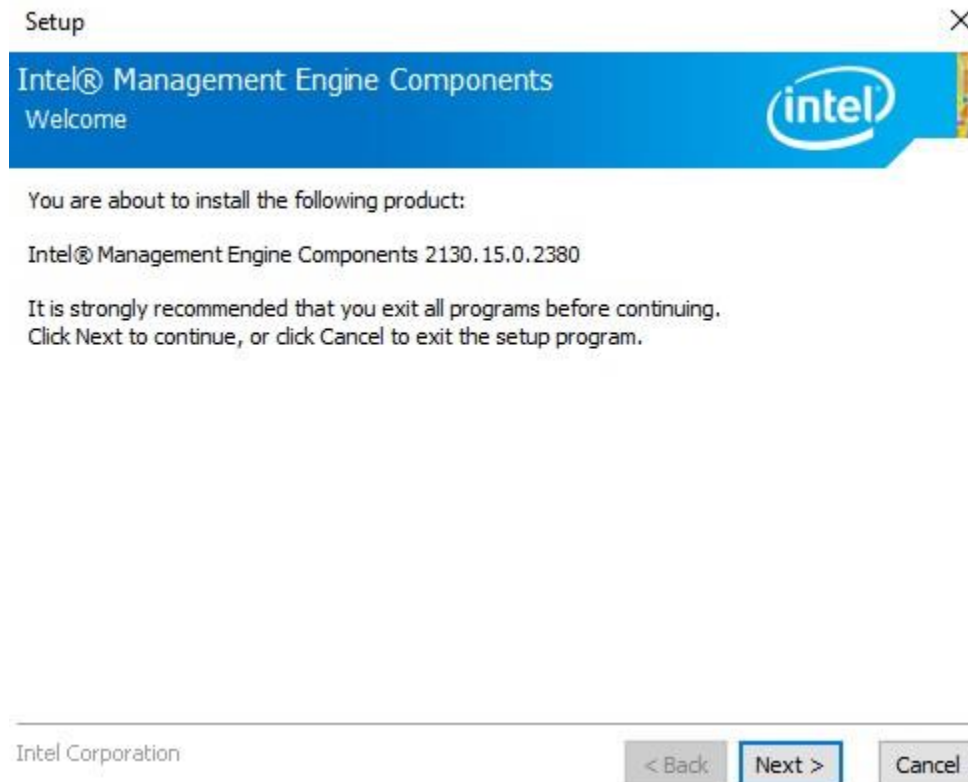

Step 2. Choose **I accept the terms in the License Agreement** and click **Next** to continue.

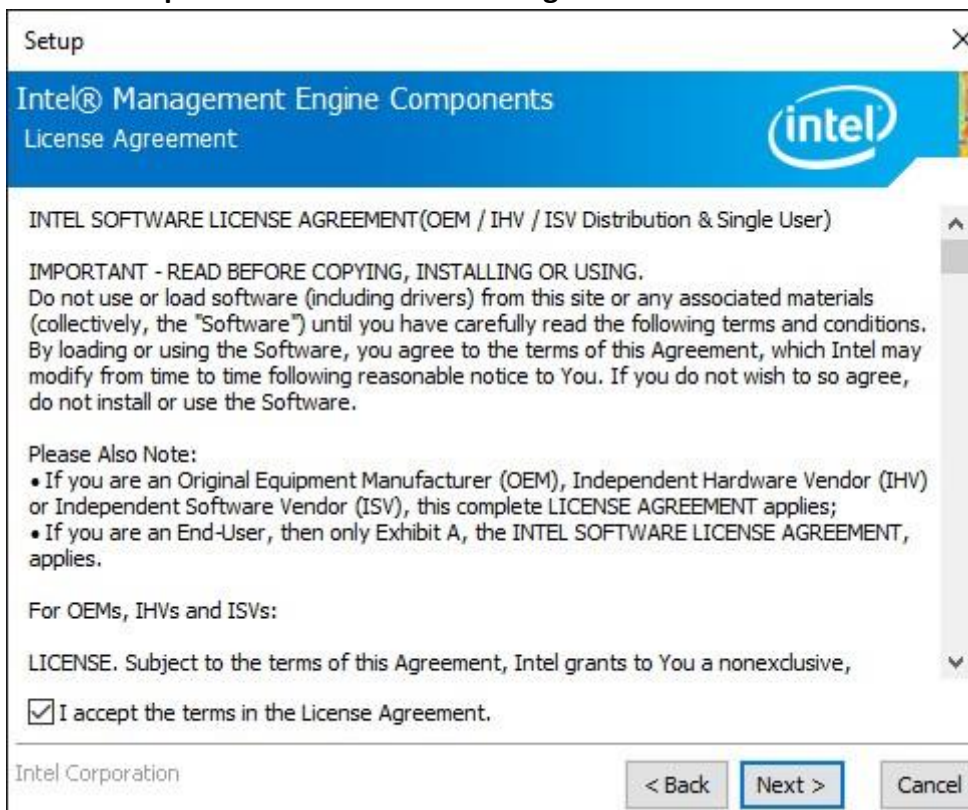

Step 3. Click **Next** to continue.

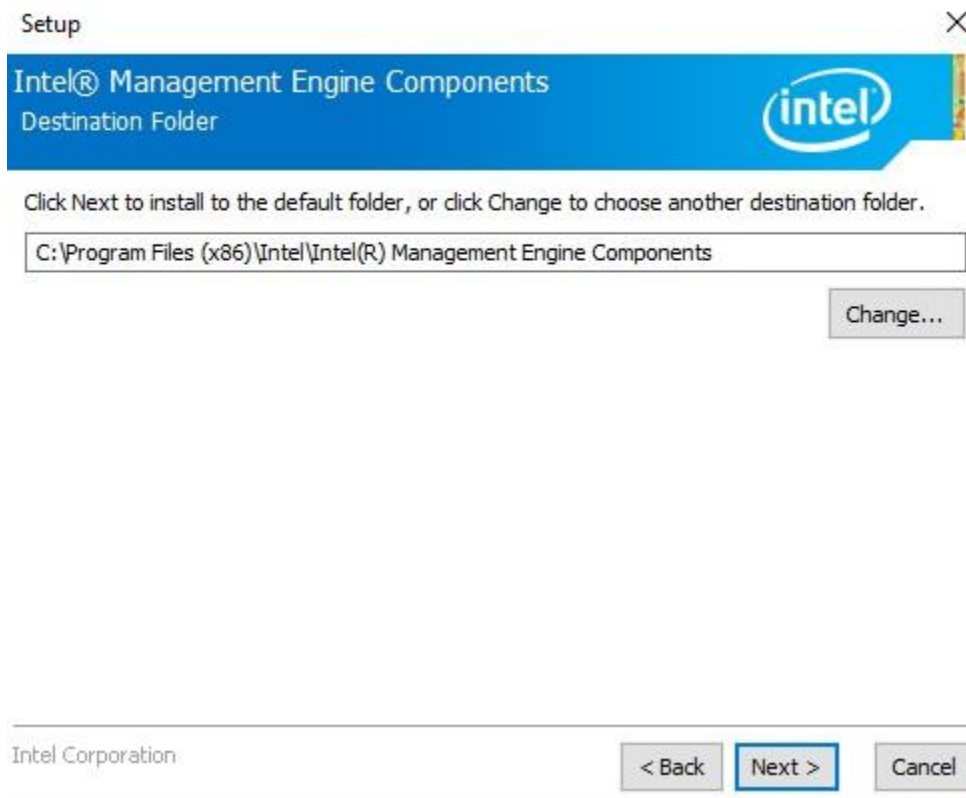

Step 5. Click **Finish** to complete installation.

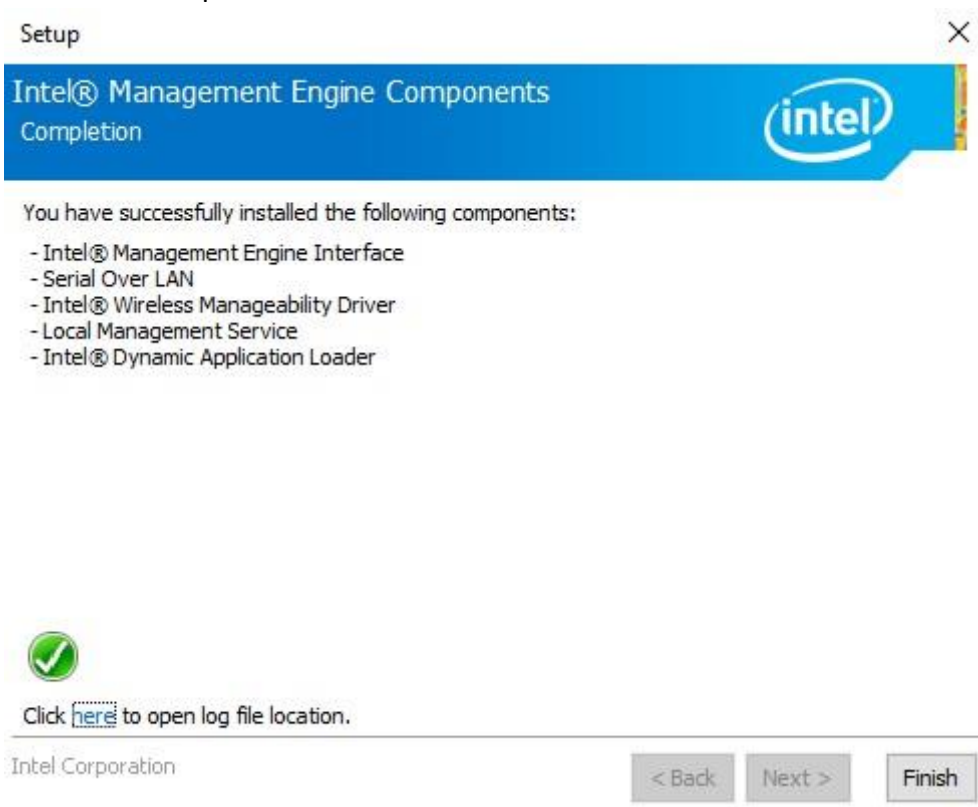

4.8 Intel® HID Event Filter

Step 1. Click **Next** to continue.

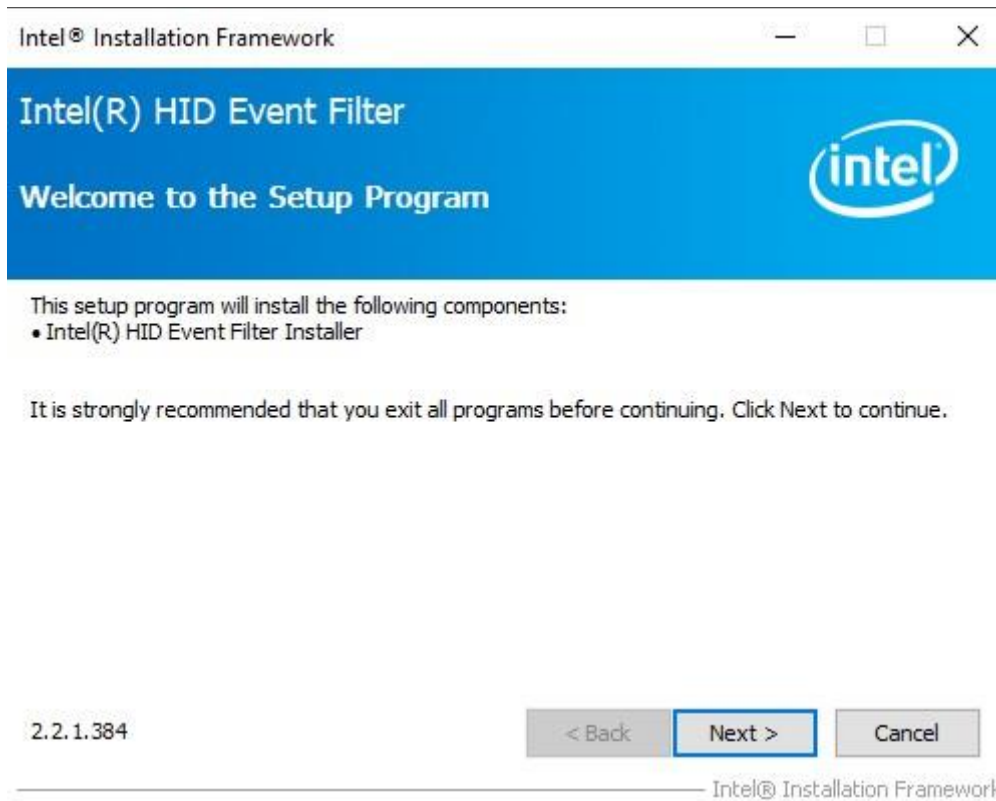

Step 2. Read the License Agreement and Click **Yes** to continue.

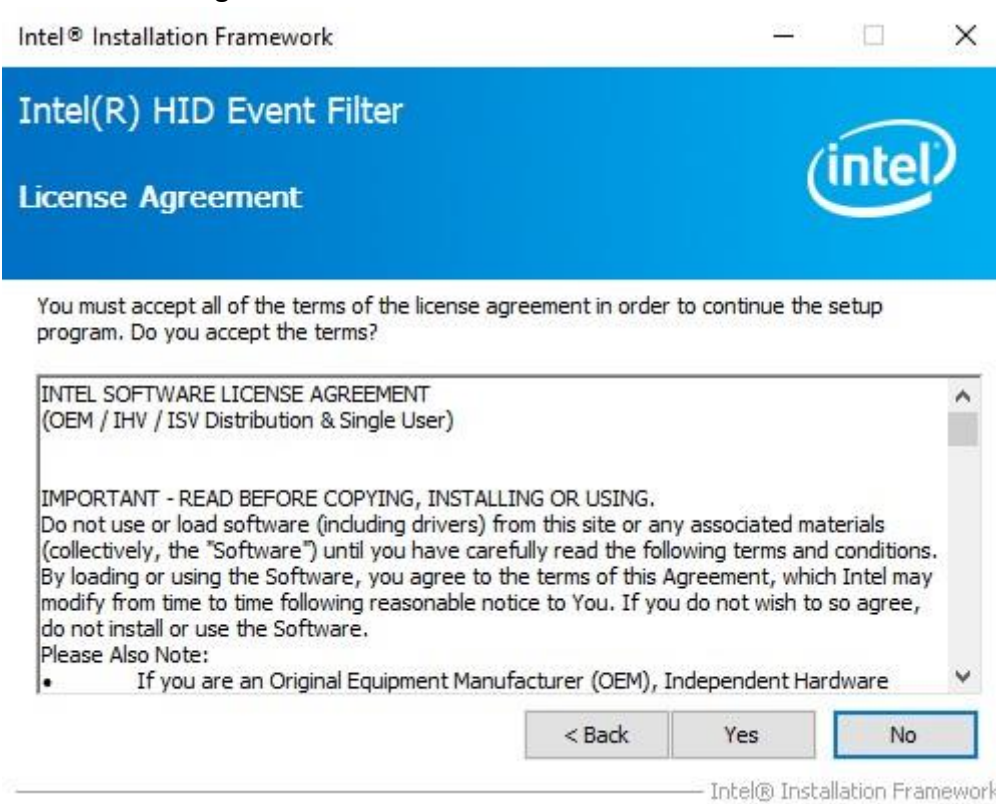

Step 3. Click **Next** to continue.

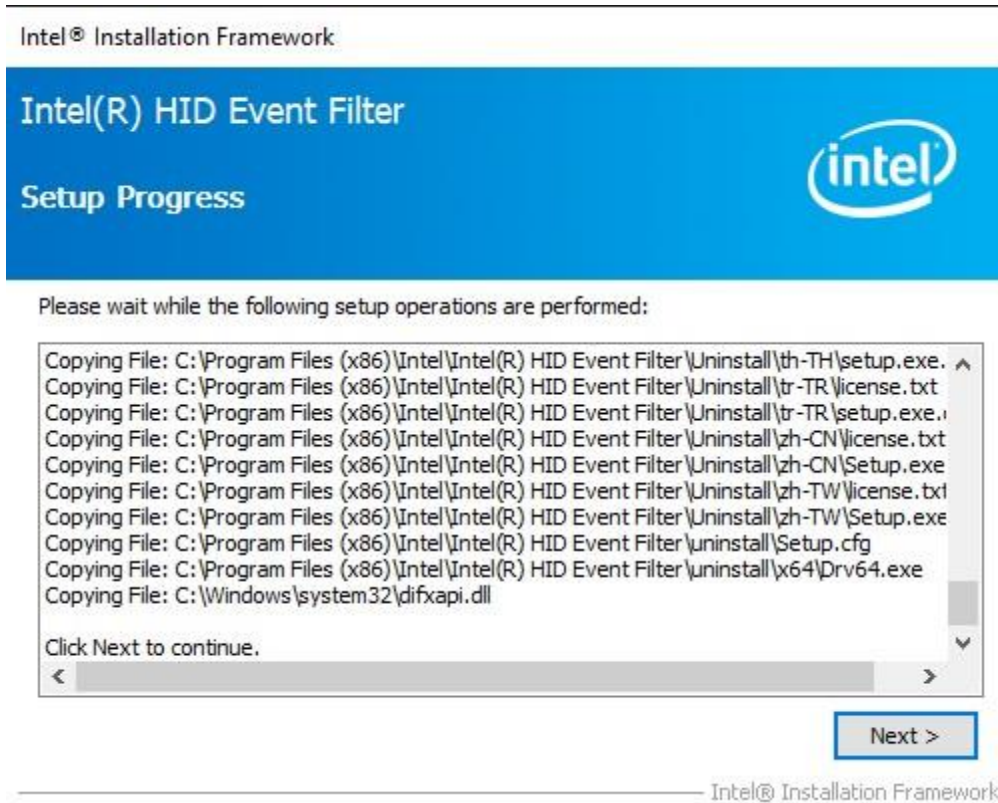

Step 4. Choose **Yes, I want to restart this computer now** and click **Finish** to finish installation.

